

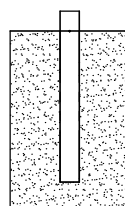

Leikin ja liikunnan edelläkävijä.

8017 Leikkikeskus asennusohje

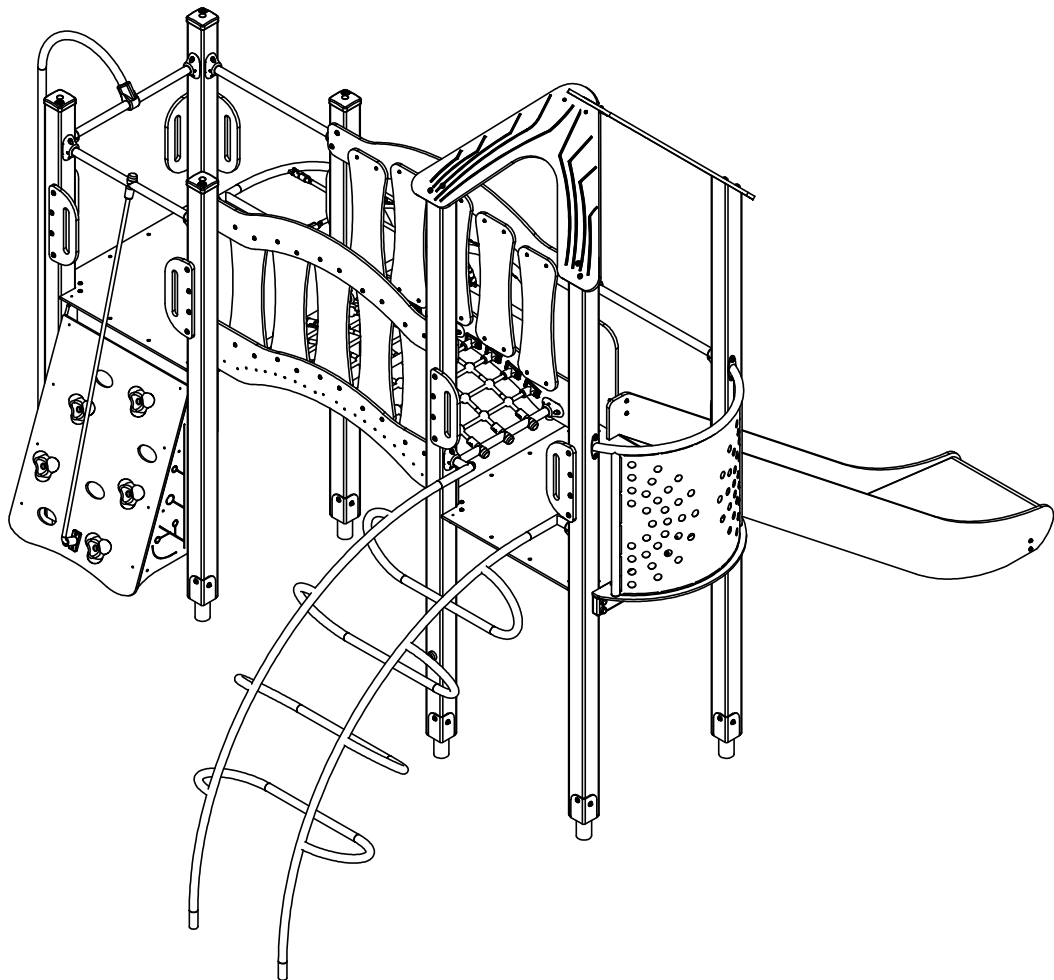

8017N
ankkuri

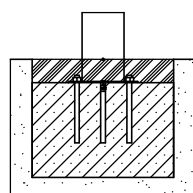

8017F
pinta

8017N

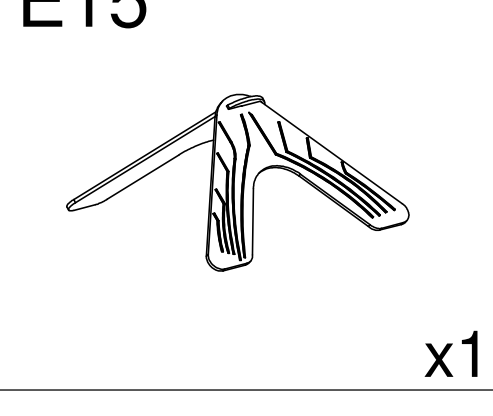
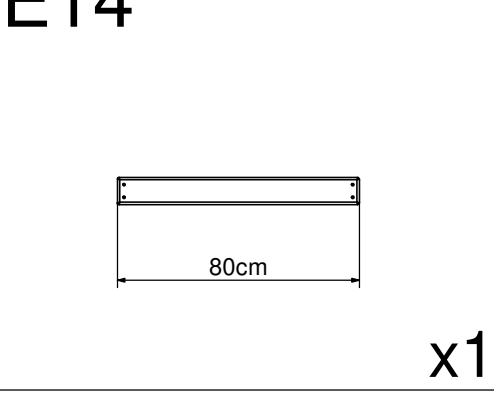
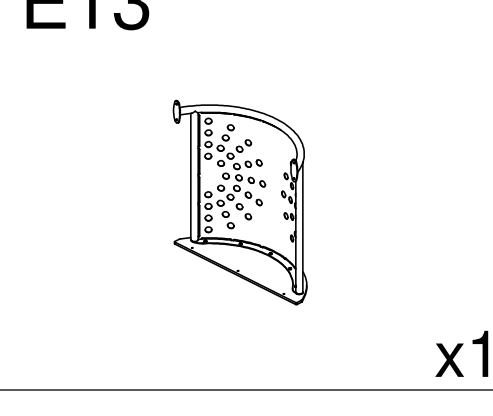
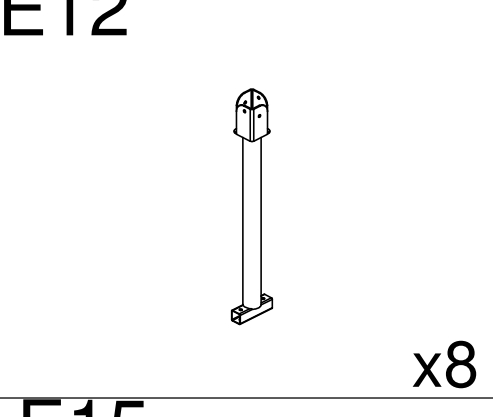
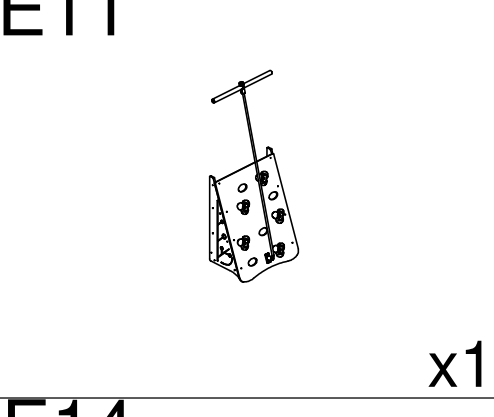
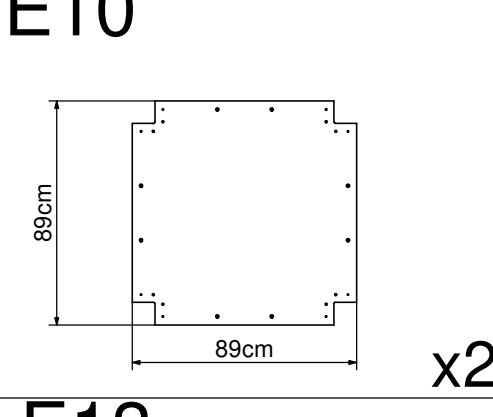
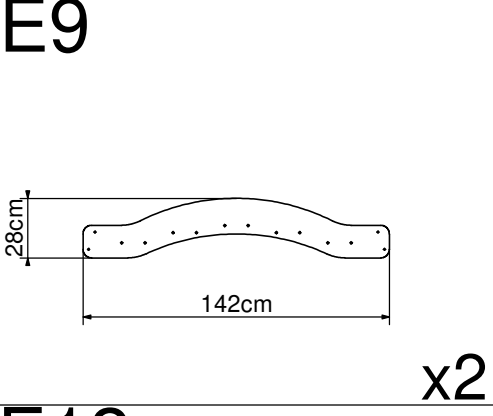
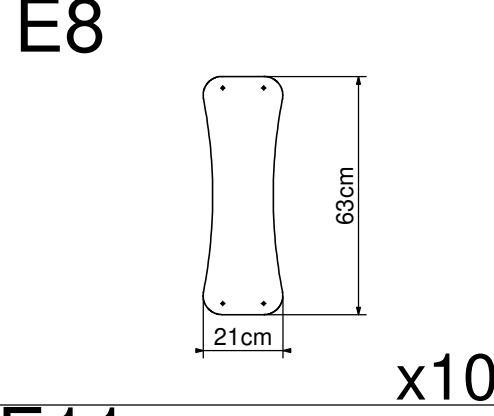
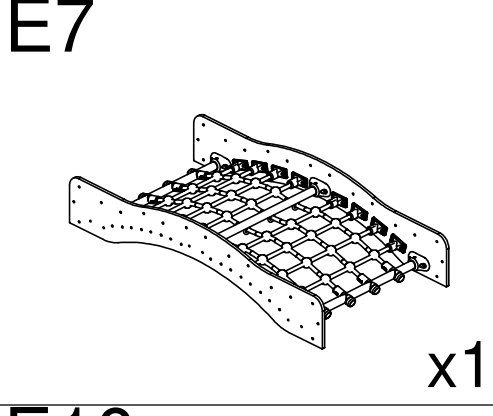
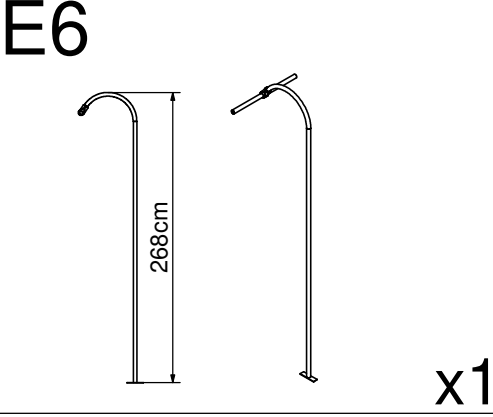
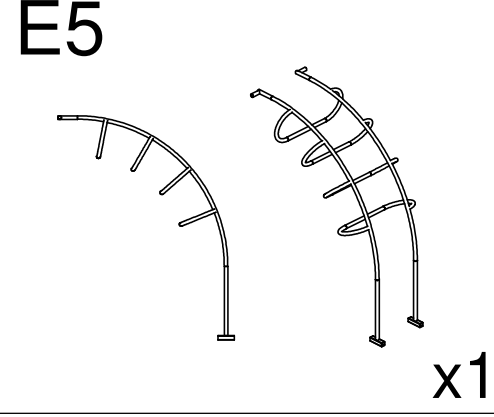
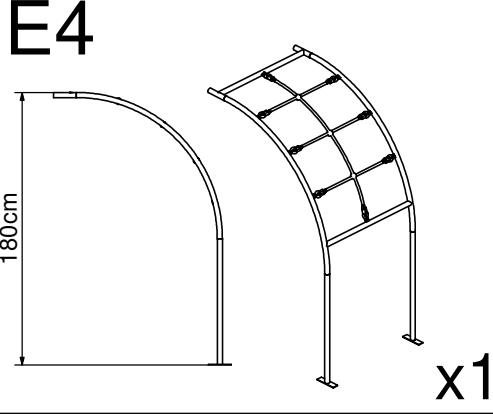
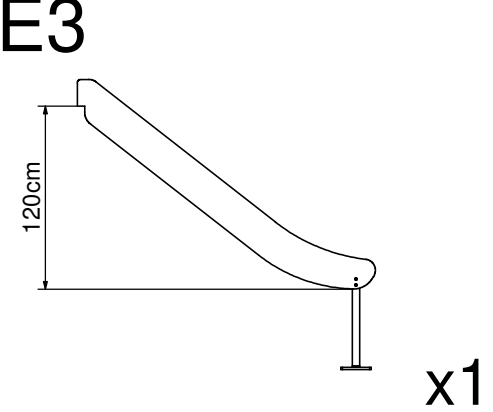
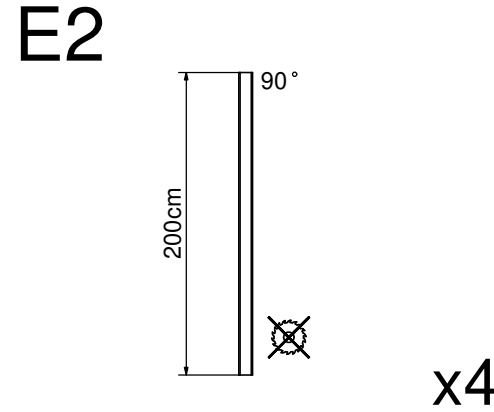
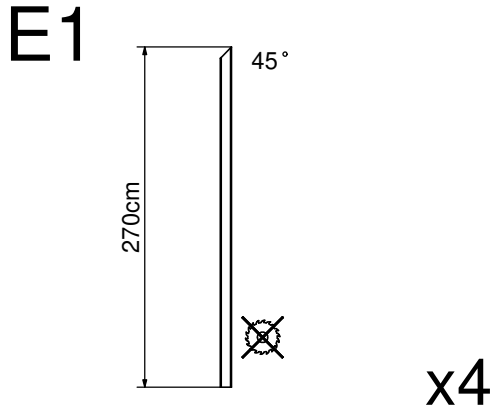

8017N

E16



L=70 cm

x2

E17

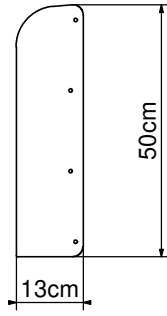

x2

E18

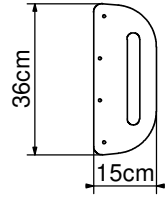

x8

E19

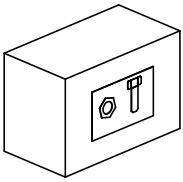

x1

8017F

E1

270cm
45°
x4

E2

200cm
90°
x4

E3

120cm
x1

E4

125cm
x1

E5

x1

E6

213cm
x1

E7

x1

E8

63cm
21cm
x10

E9

28cm
142cm
x2

E10

89cm
89cm
x2

E11

x1

E12

15cm
x8

E13

x1

E14

80cm
x1

E15

x1

8017F

E16



L=70 cm

x2

E17

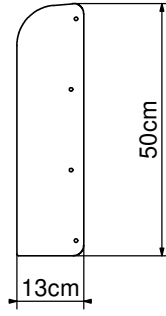

x2

E18

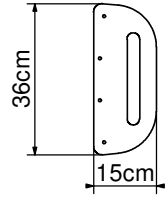

x8

E19

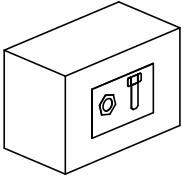



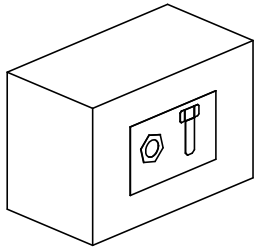





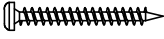





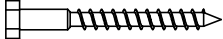

x1



8017N





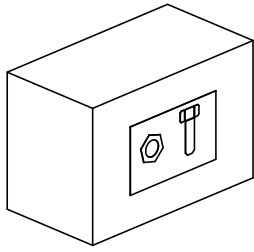

8017F

Nr	Element			Σ	Σ
1		-	S6x60	162	162
2		-	W6x60	133	133
3		-	K2_d30_B	1	1
9		ISO 7380	M6x25	40	40
10		DIN 9021	6x18	4	4
16		-	K1_d21_B	4	4
17		-	Z1_d21_B	4	4
20		DIN 571	8x80	4	4
21		DIN 125	8x16	93	97
22		DIN 125	6x12	48	52
24		ISO 7380	M6x16	8	12
29		-	K_5_A2_g2_ G_v2	4	4
58		-	LIIMA	1	1
61		-	KL105	/	37
109		DIN 913	10x10	24	24
121		-	7100_5_A2_ g3_G_v1	/	2
146		DIN 7991	M6x12	16	16



8017N

8017F

Nr	Element			Σ	Σ
147		-	M6x10	64	68
148		-	CONET ECO	8	8
149		-	ALUZ SD	12	12
179		-	Z_ECO_1	4	4
180		-	K_ECO_1	4	4
213		-	Z_NA_1	1	1
214		-	Z_NA_2	1	1

8017N
8017F

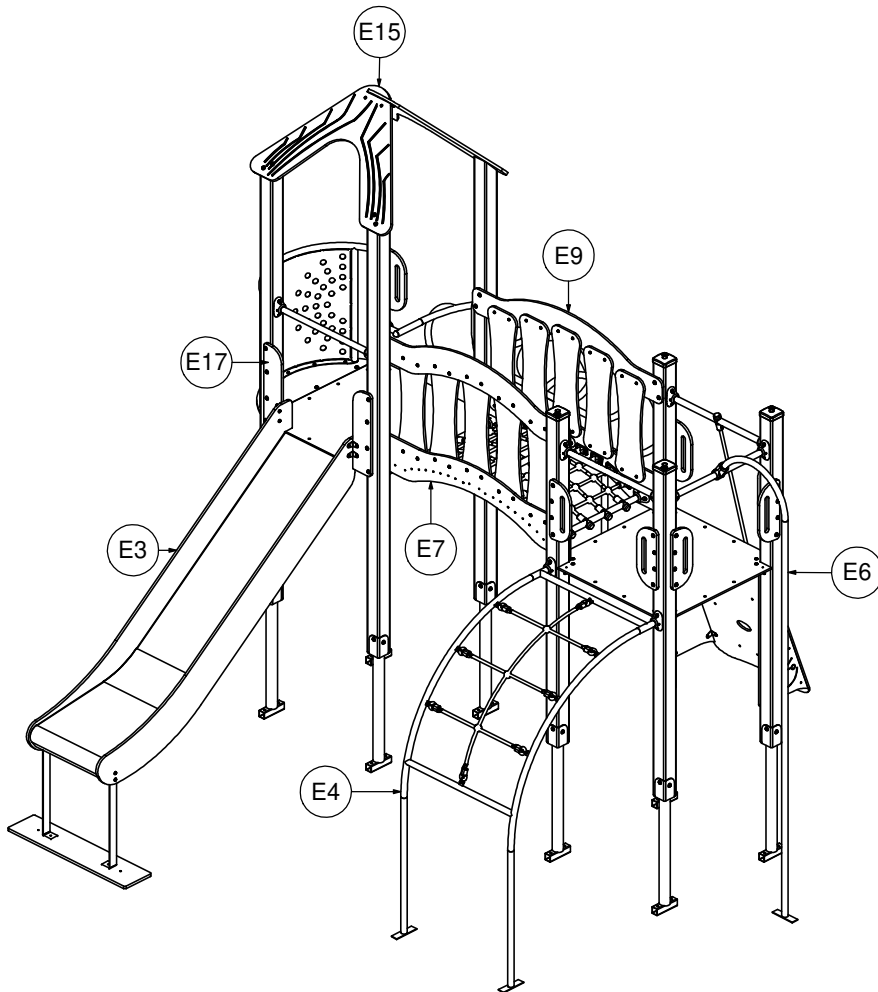
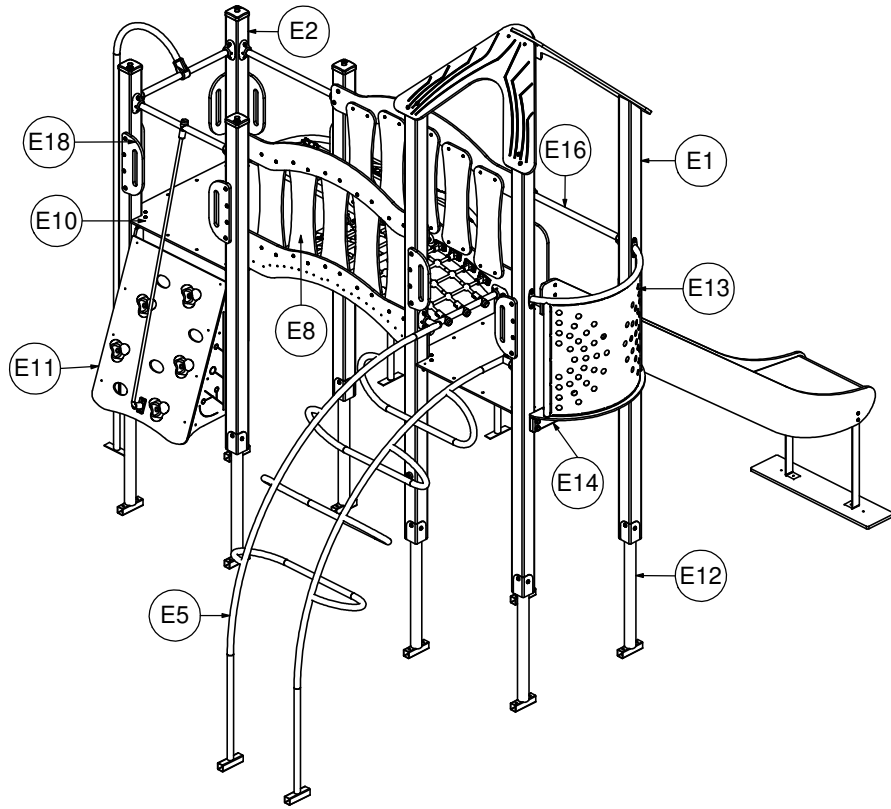

1

8017N
8017F

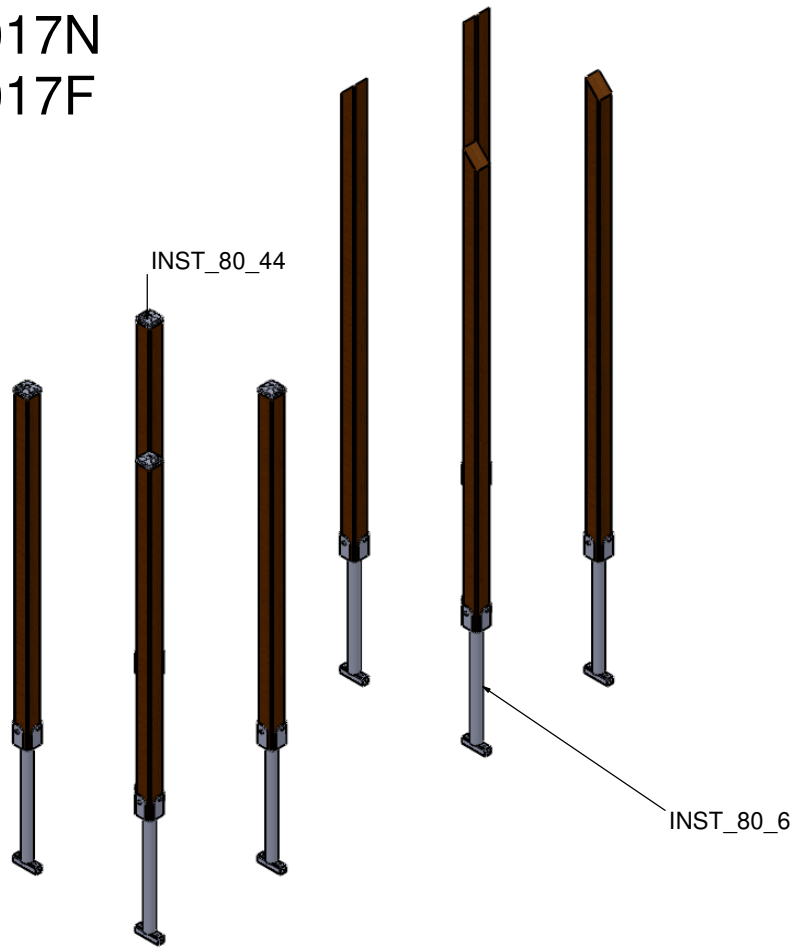

2

8017N
8017F

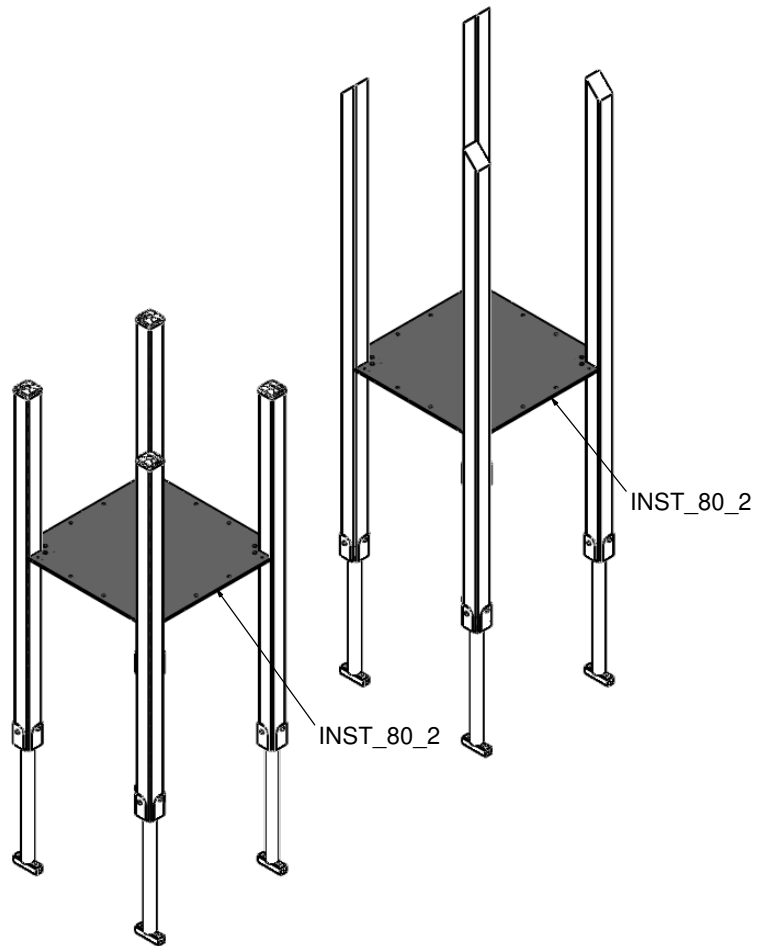

3

8017N
8017F

INST_80_19

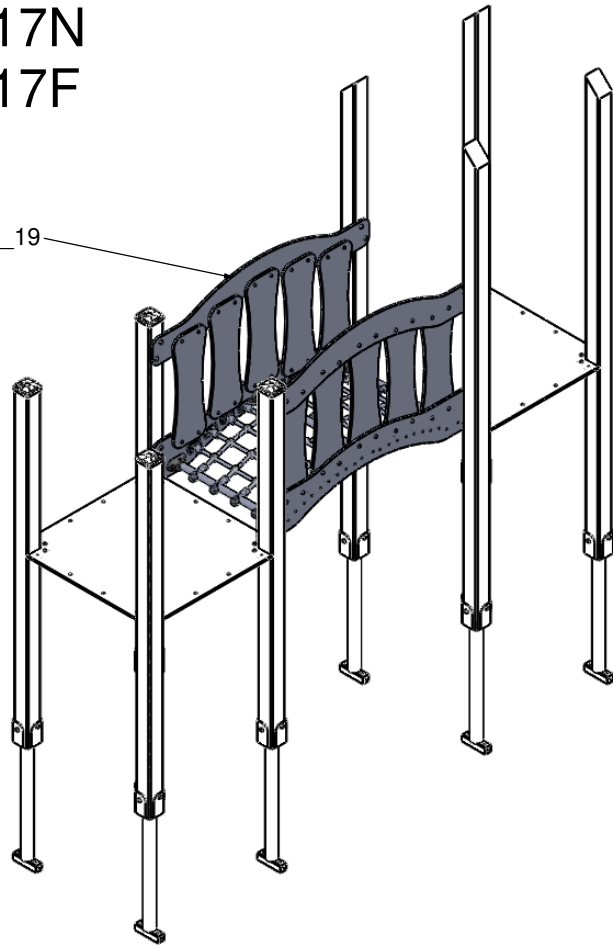

4

8017N
8017F

INST_80_15

INST_80_1

INST_80_14

INST_80_16

INST_80_8

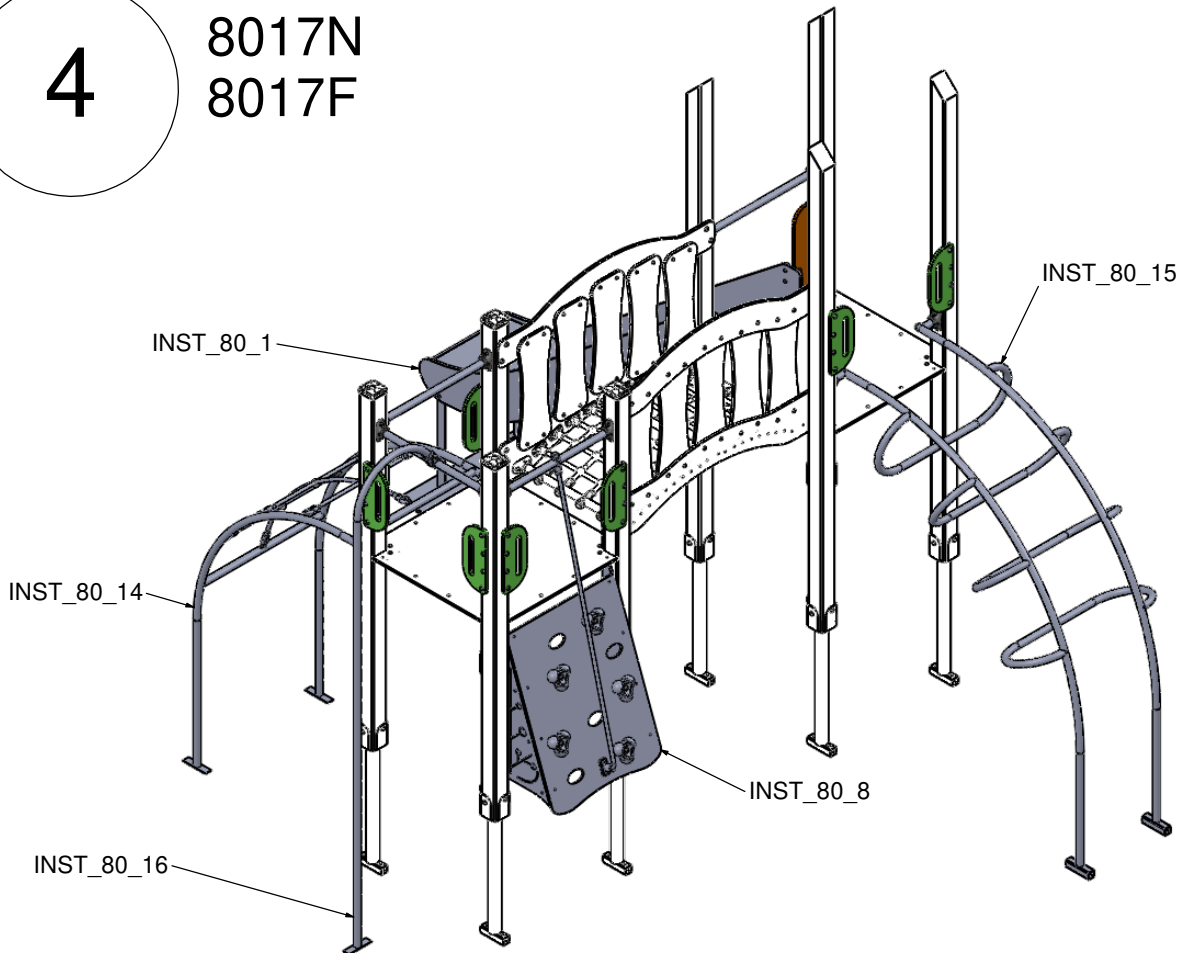

5

8017N
8017F

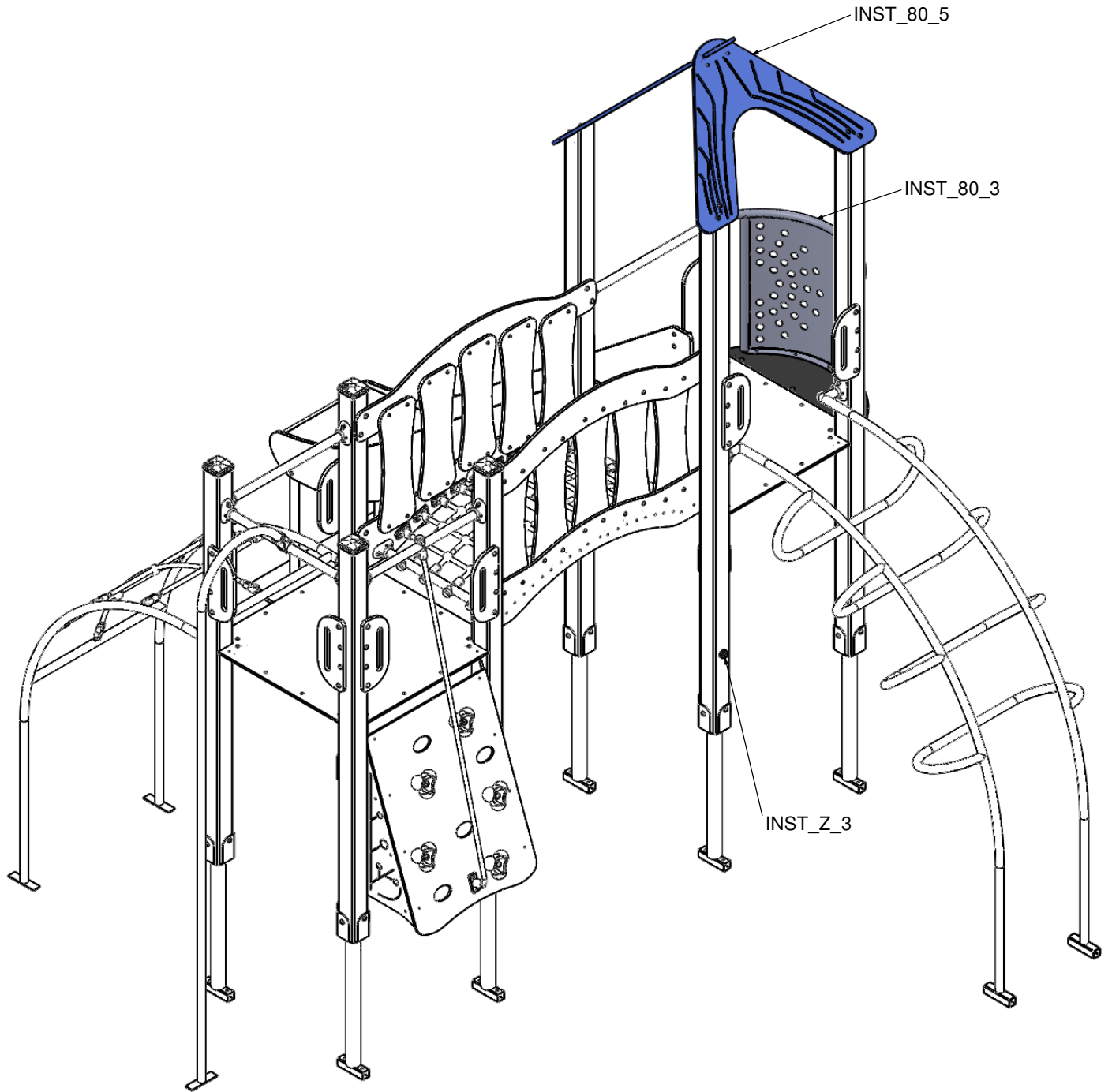

8017N

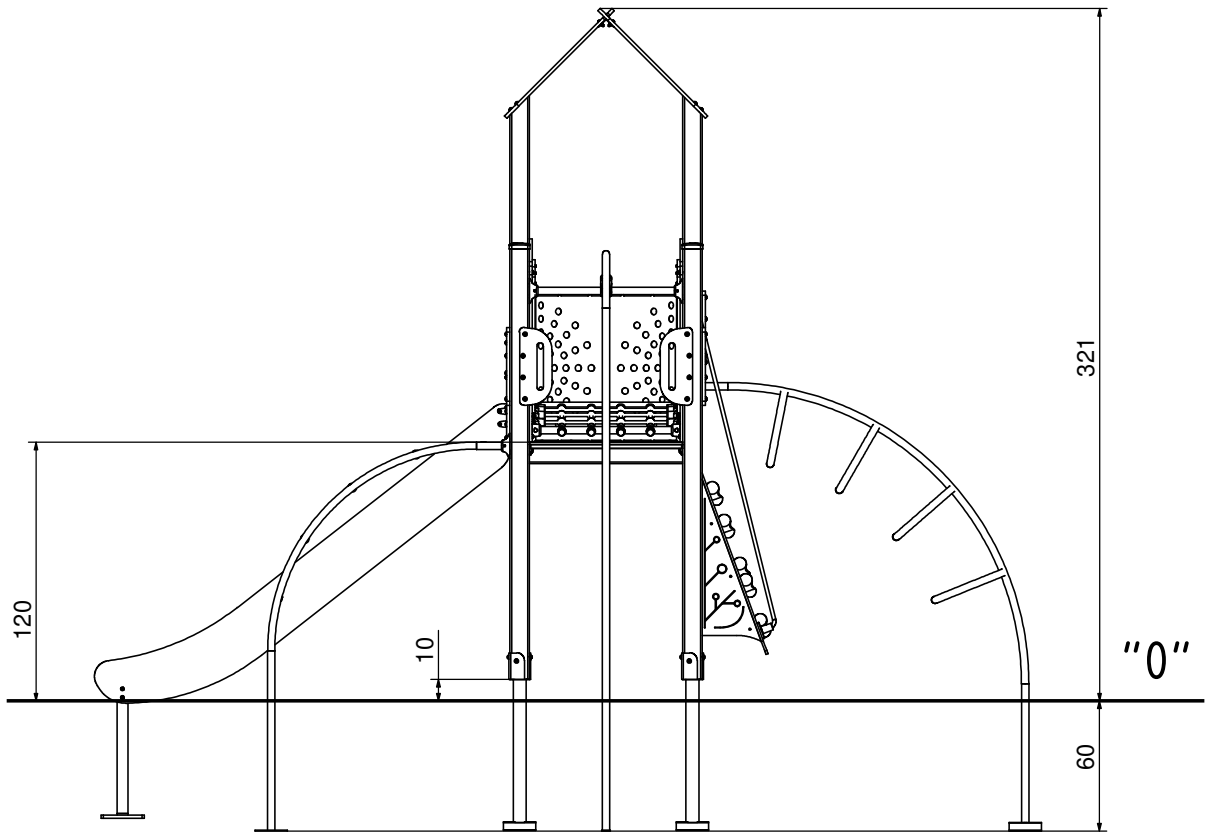
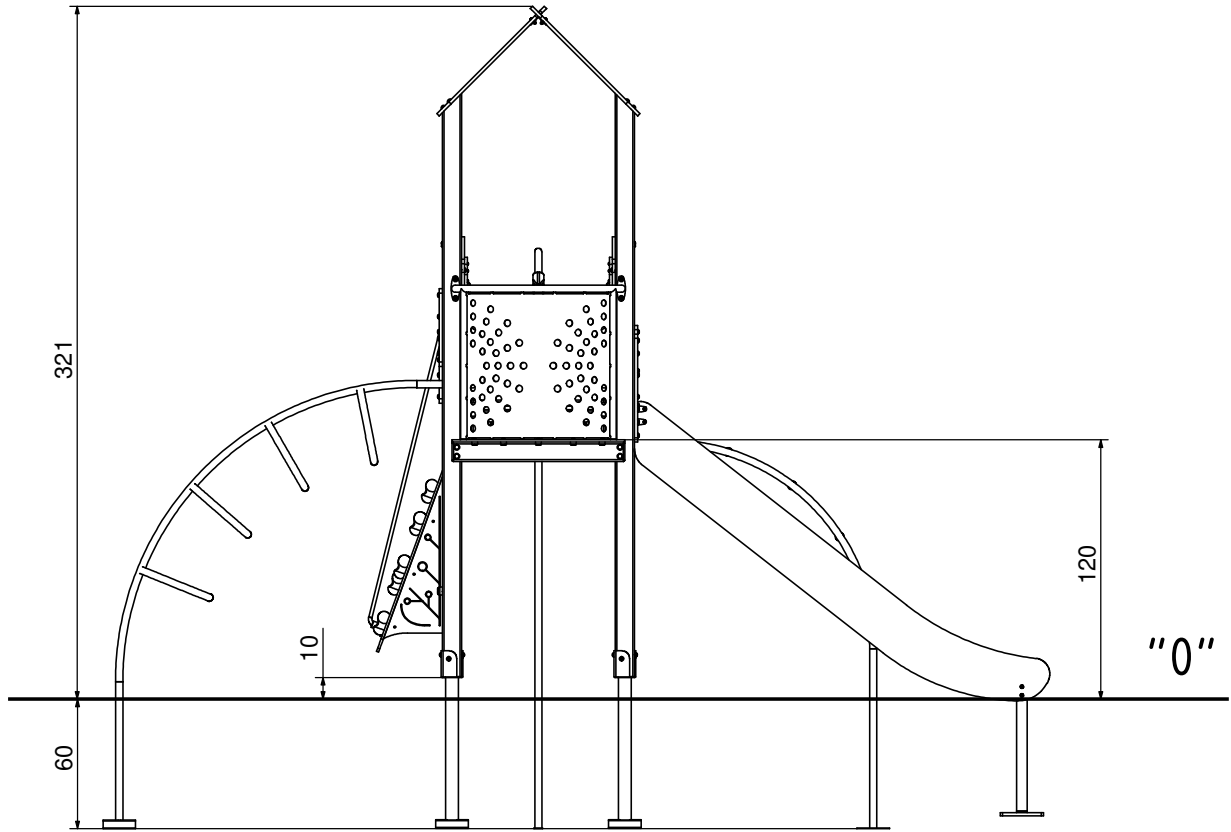

8017F

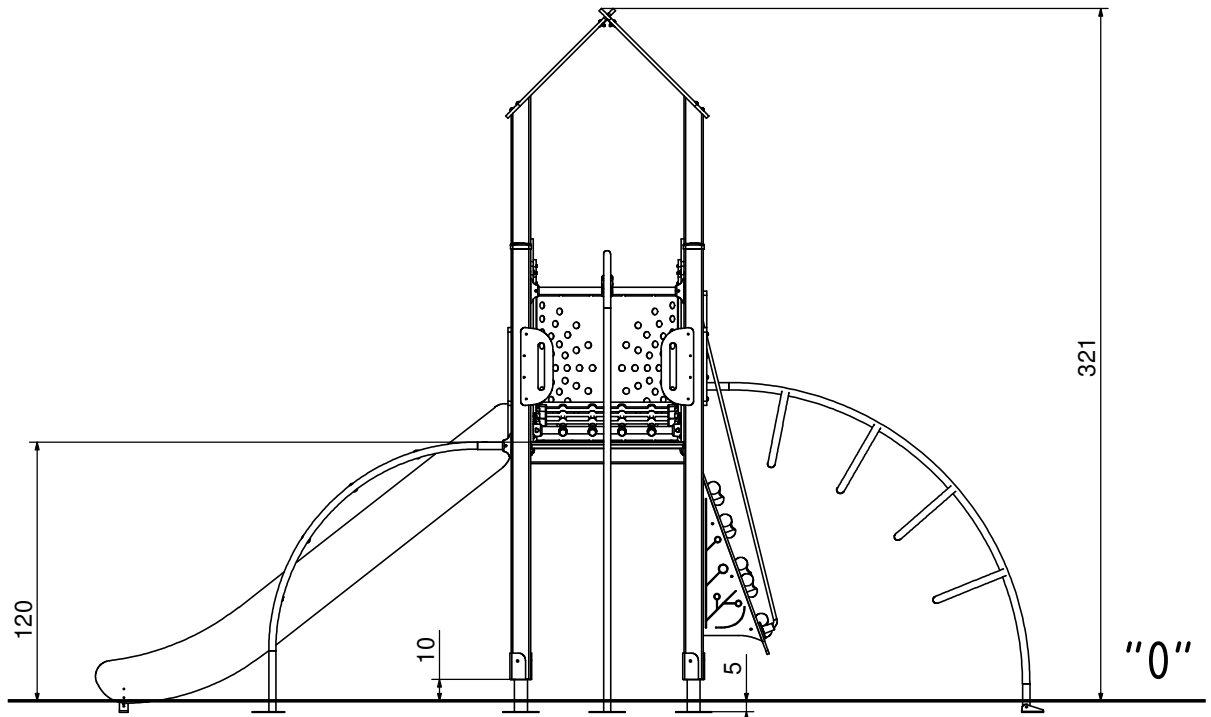
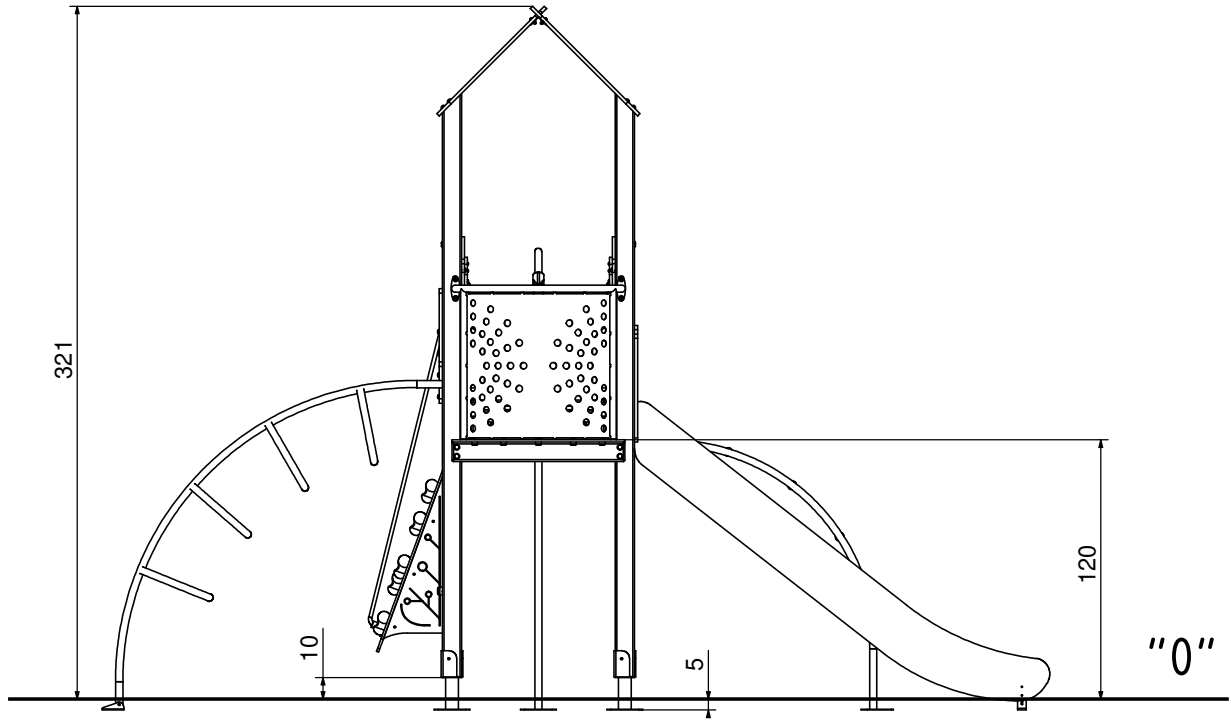

8017N

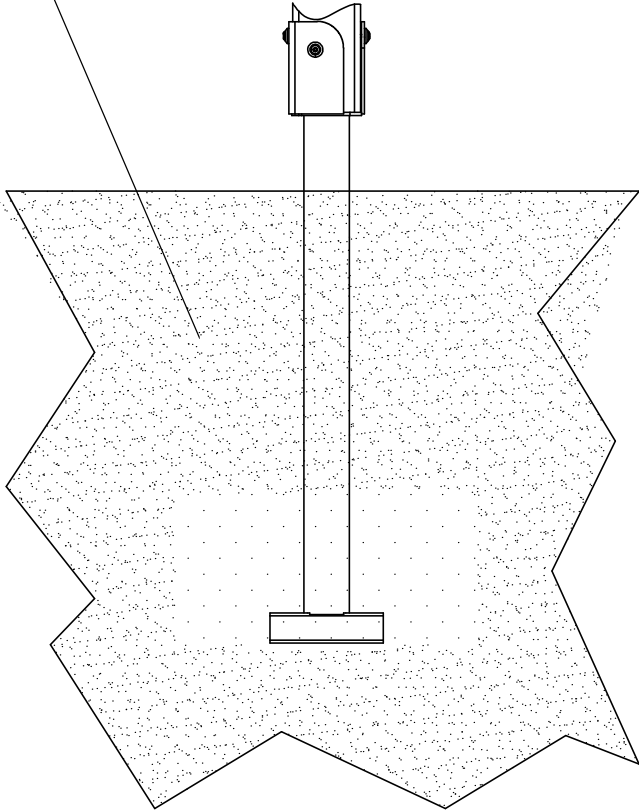
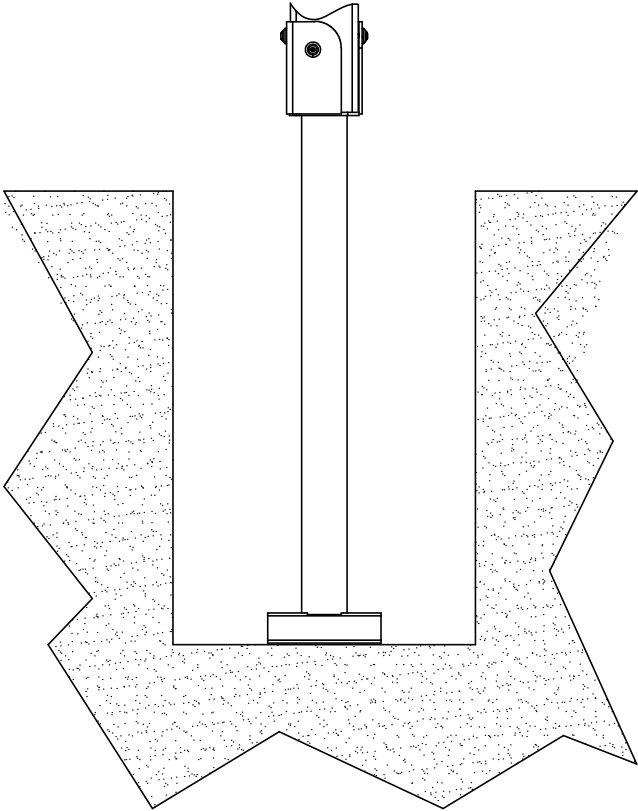
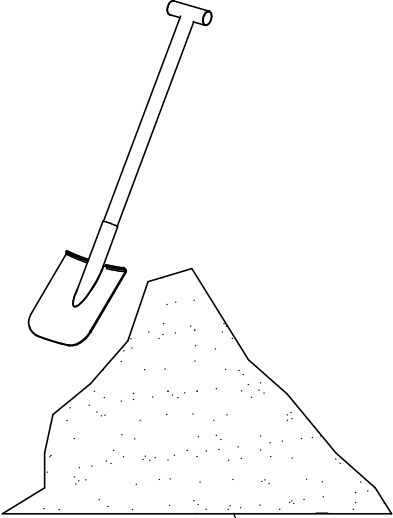
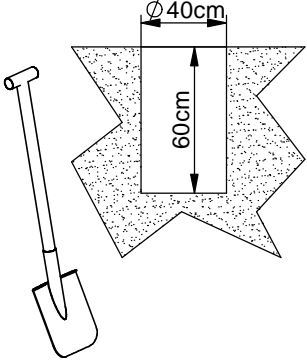

8017F

I

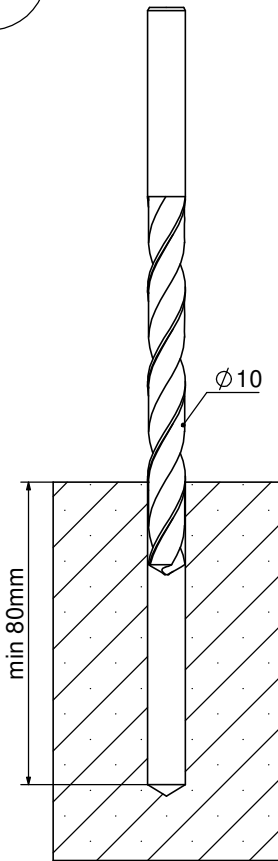

II

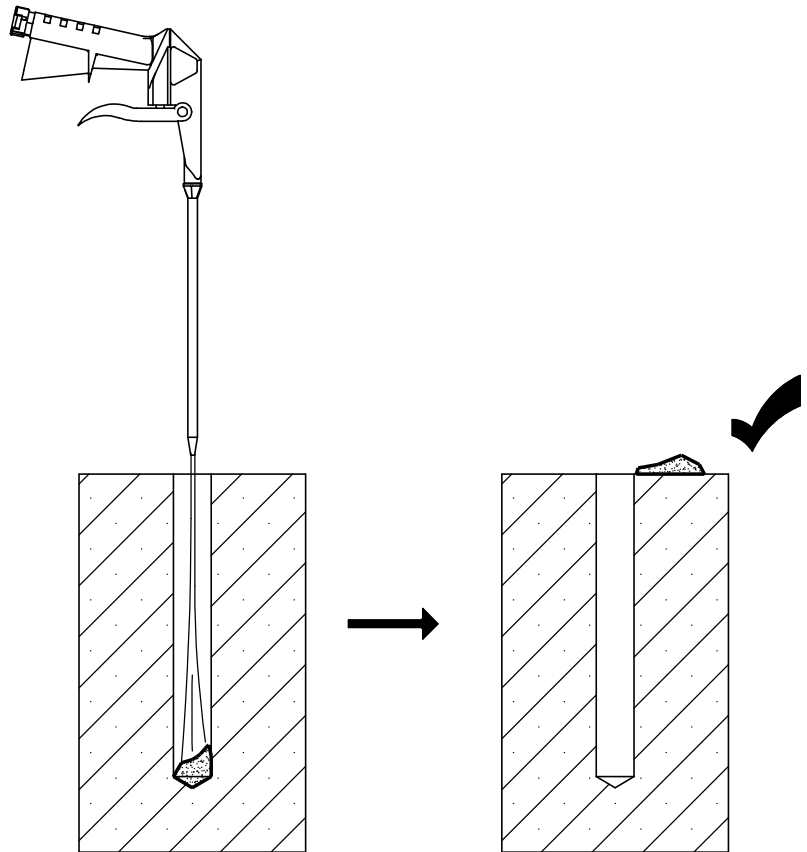

III

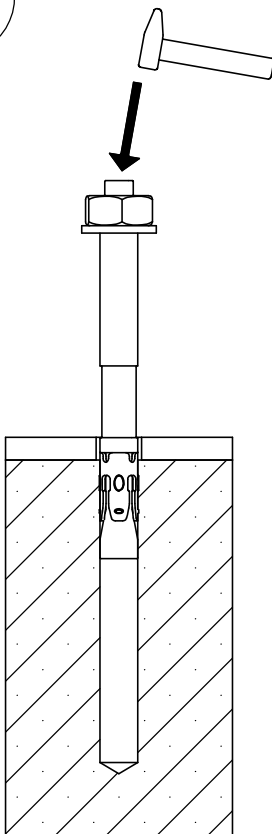

IV

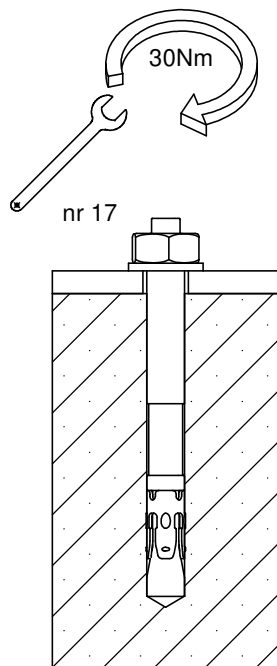

V

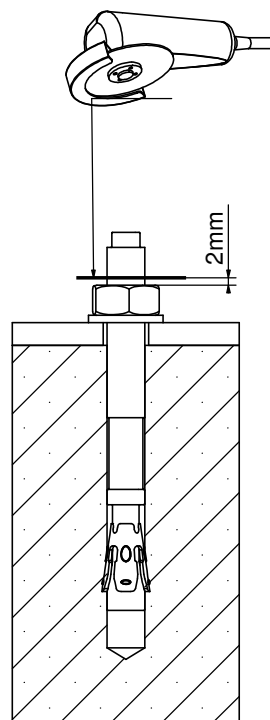



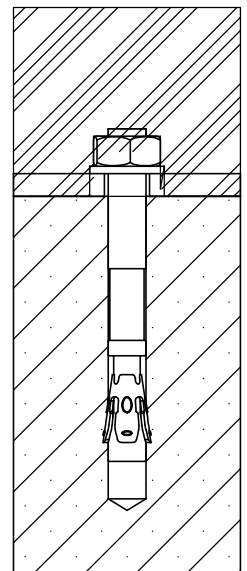



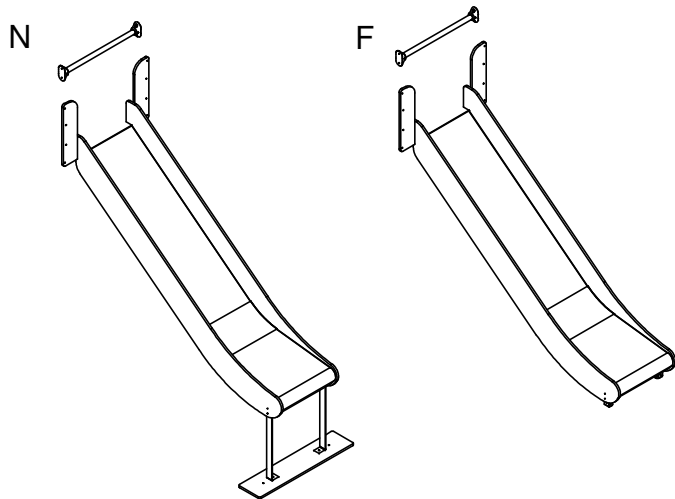

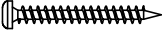
VI



INST_80_1



Nr:	Σ	Element:	
1	12x	S6x60	
2	8x	W6x60	
21	12x	DIN 125 - 8x16	
22	8x	DIN 125 - 6x12	
24	8x	ISO 7380 - M6x16	
29	4x	K_5_A2_g2_G_v2	
109	4x	DIN 913 10x10	
147	8x	BN M6x10	
149	2x	ALUZ SD	

1 N,F

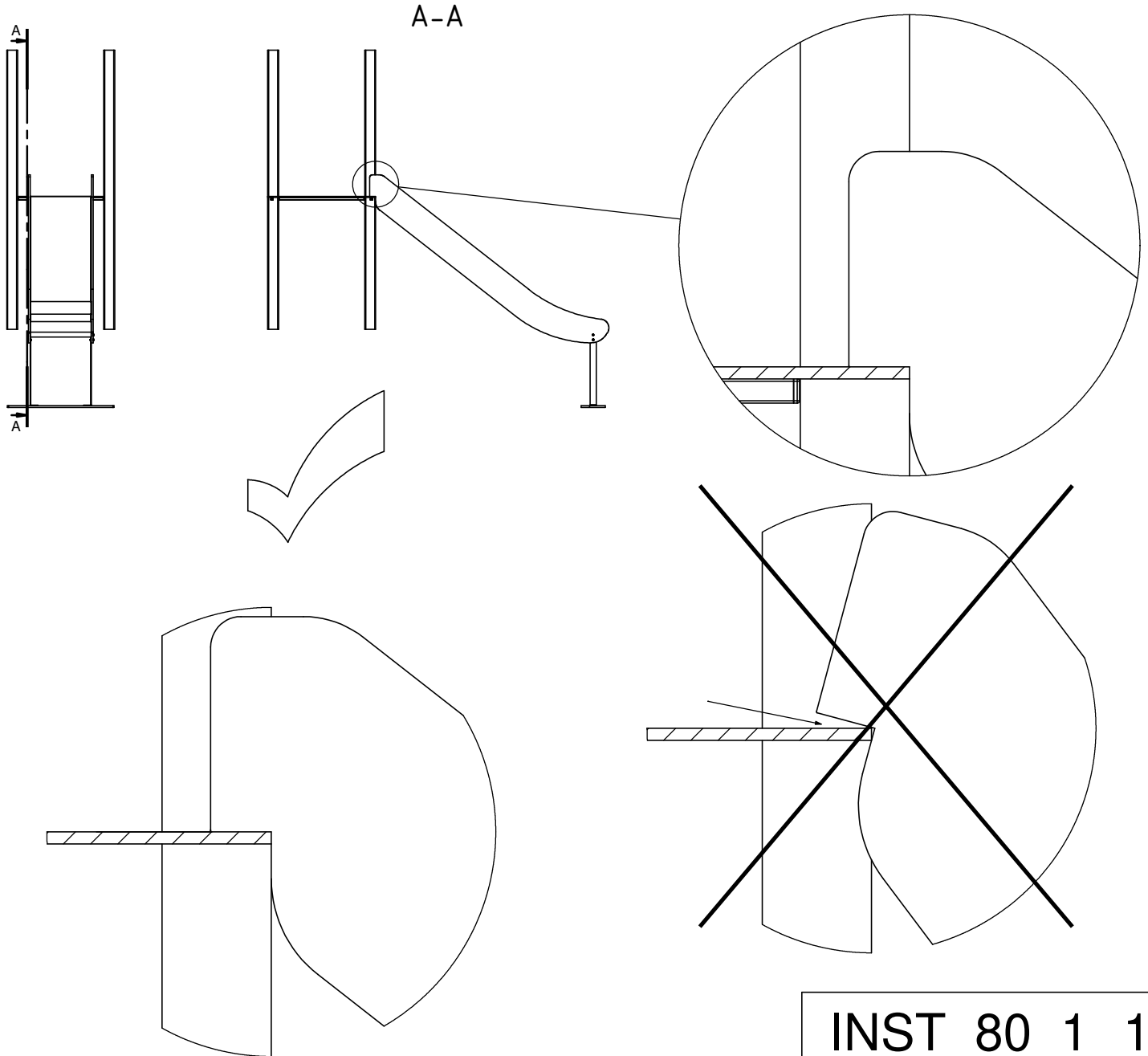

2 N,F

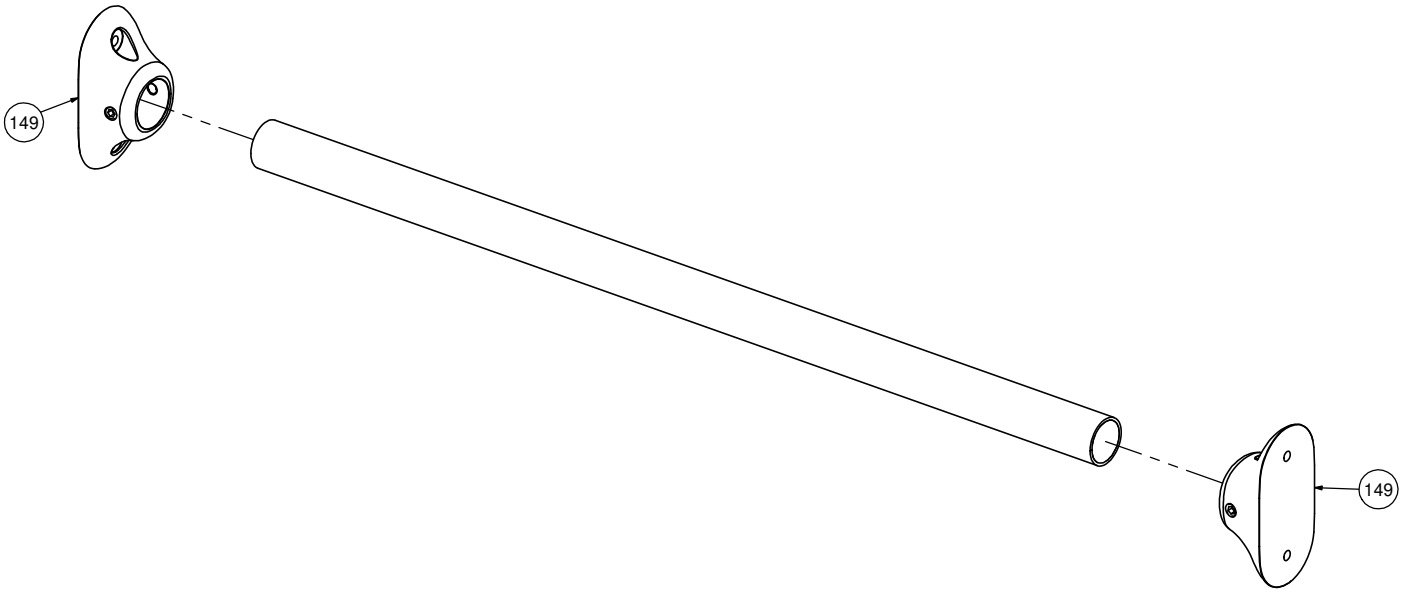

3 N,F

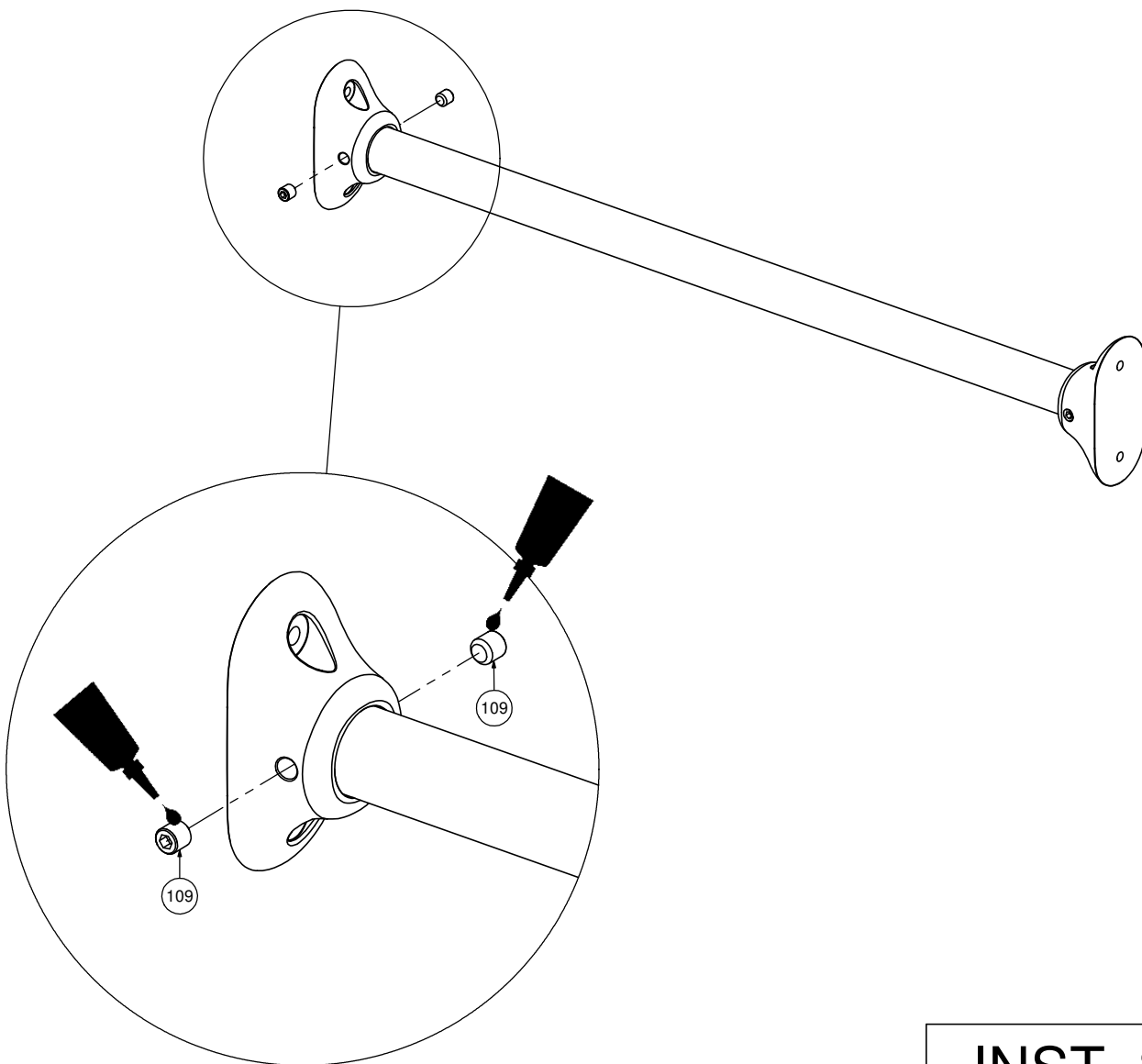

4 N,F

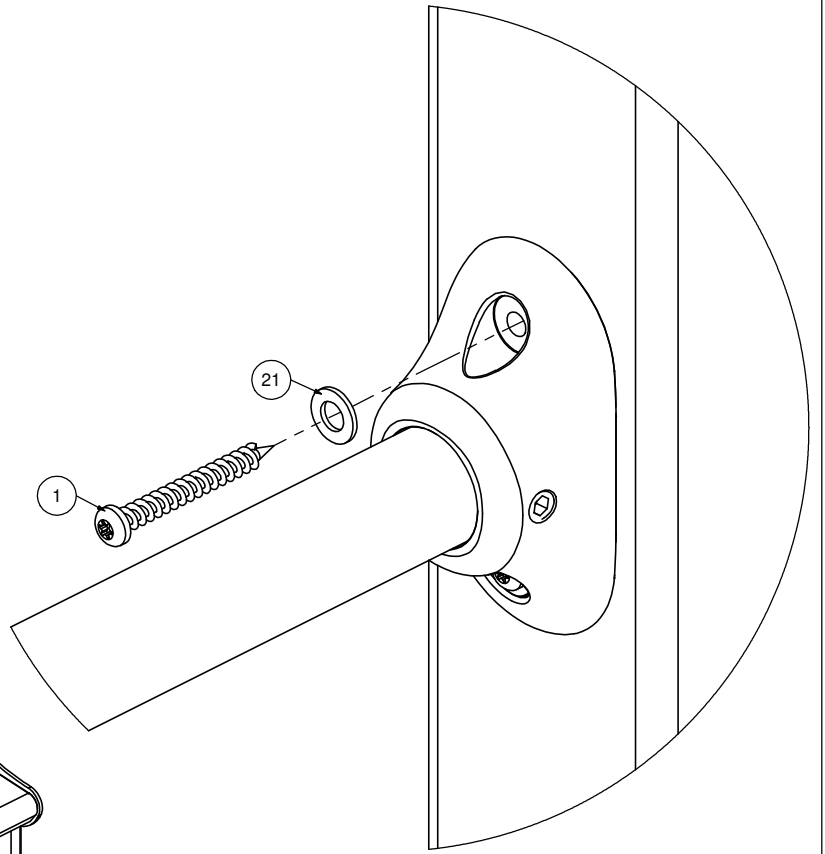
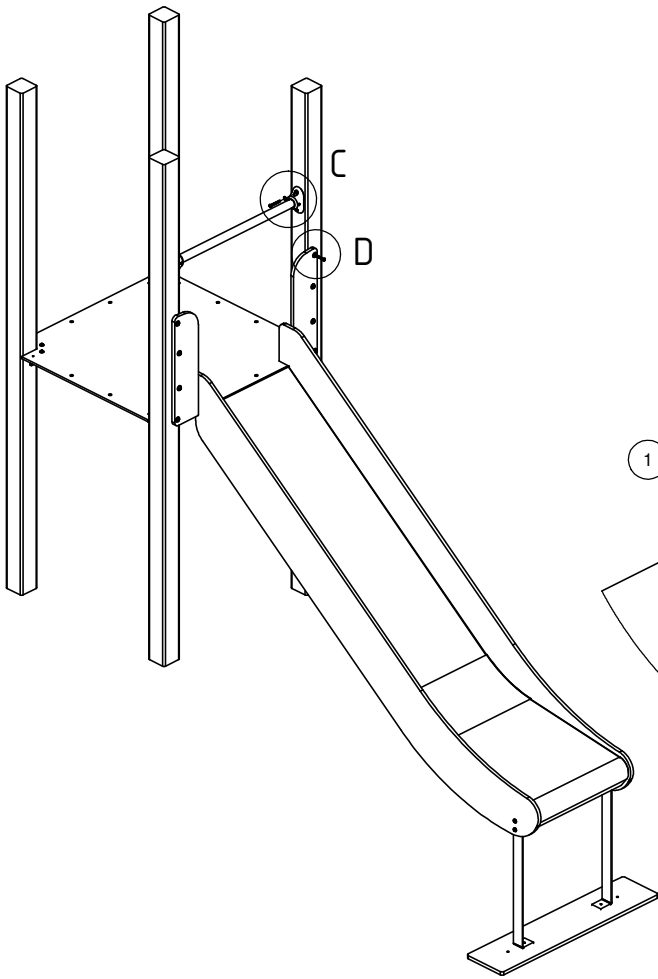

D (1 : 2)

5 N,F

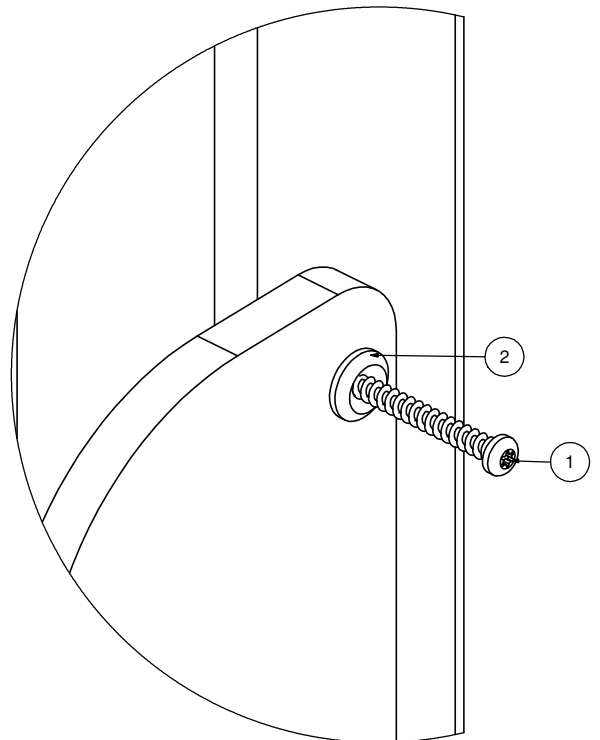
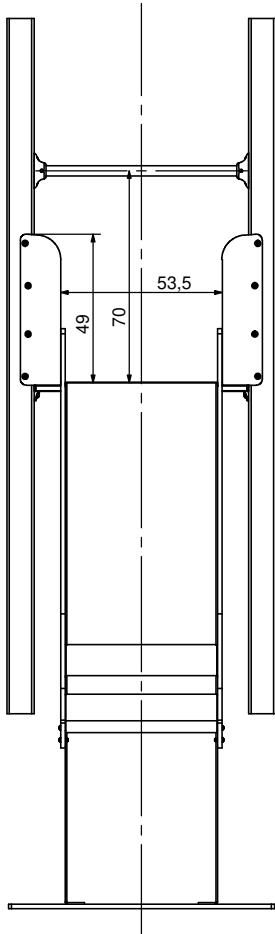





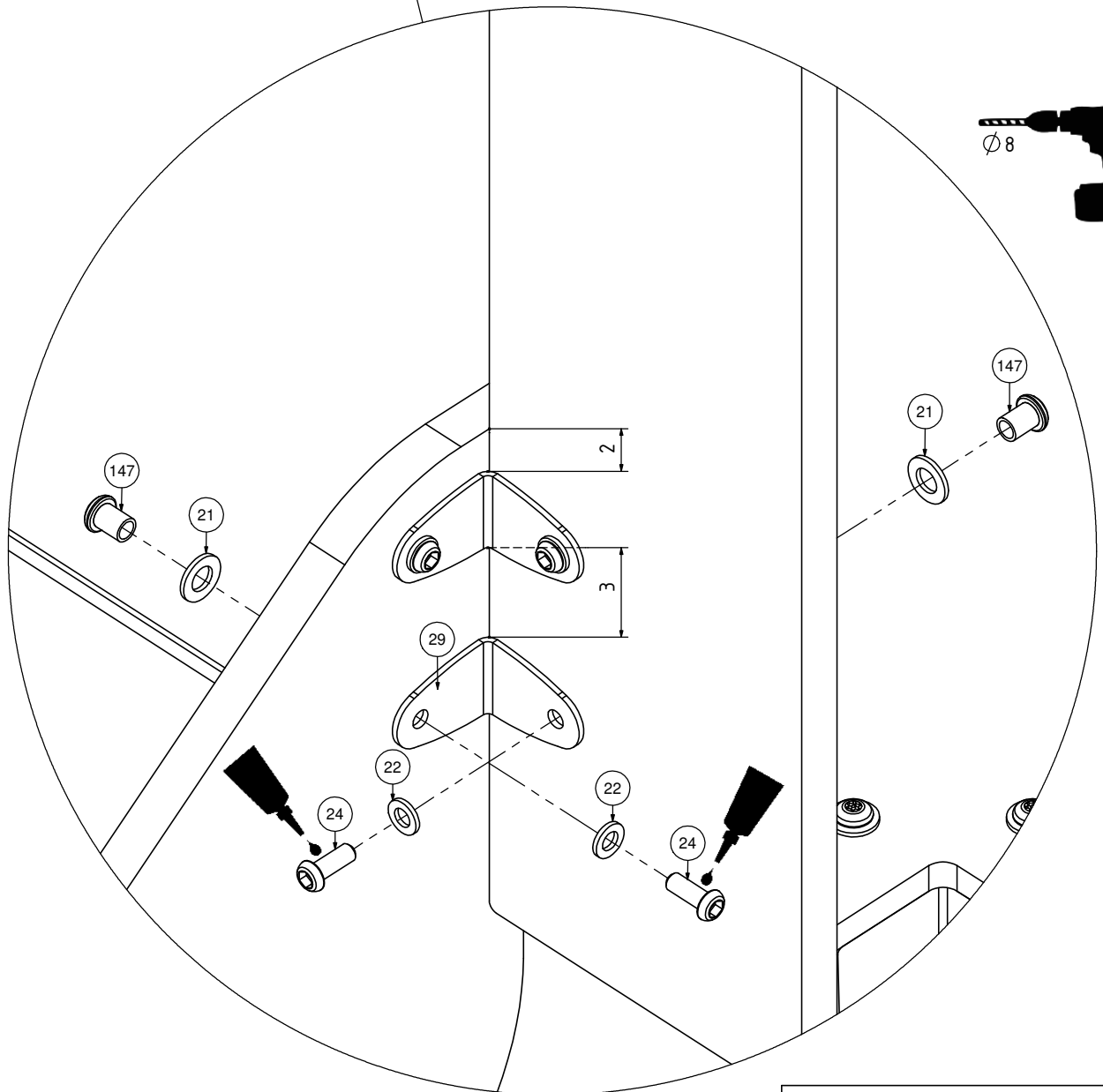
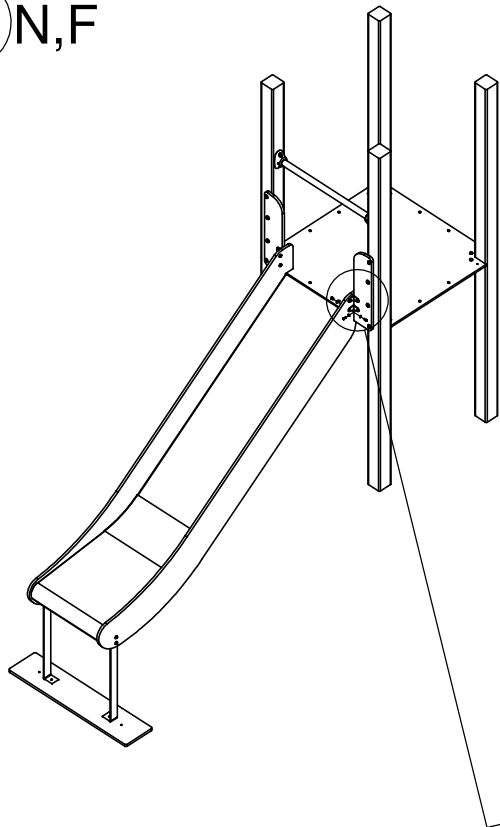

INST_80_1 3/5

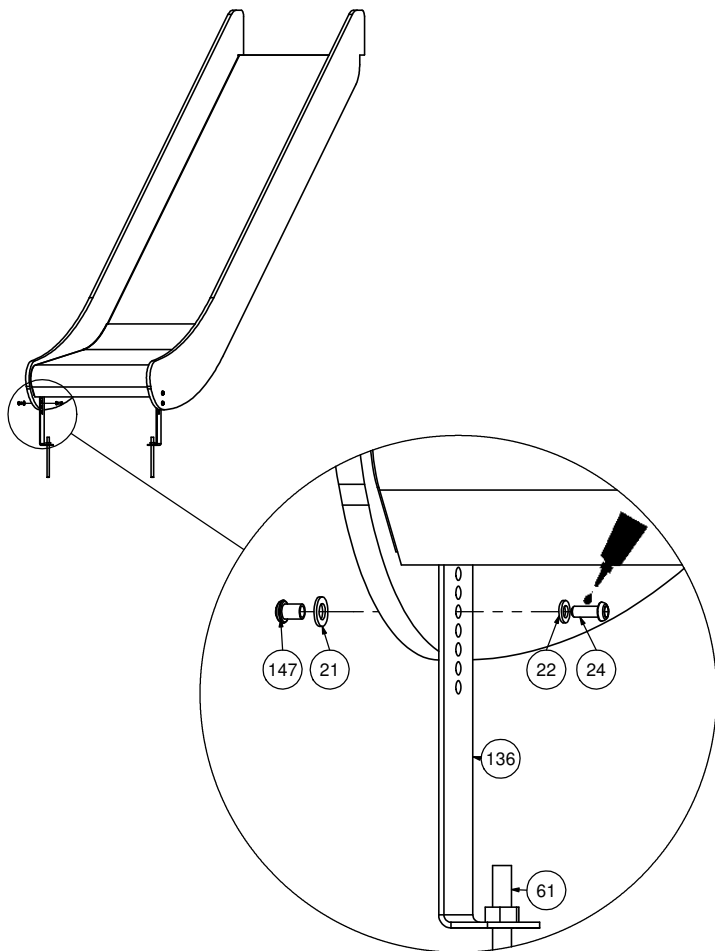
6 N,F









F - SL140

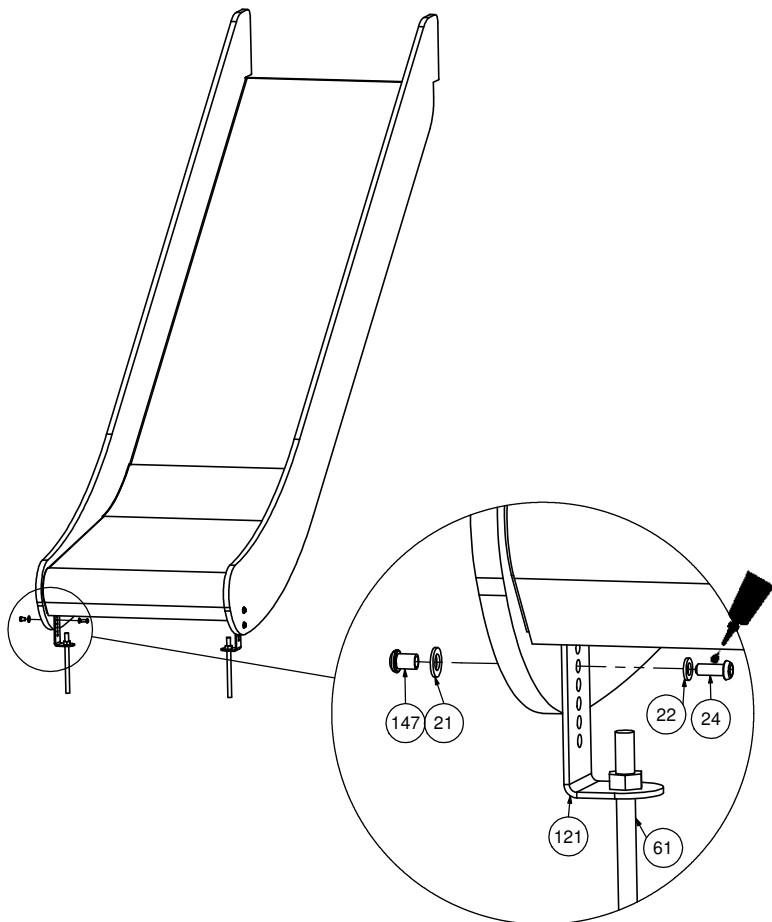







Nr:	Σ	Element:	
21	4x	DIN 125 - 8x16	
22	4x	DIN 125 - 6x12	
24	4x	ISO 7380 - M6x16	
61	2x	KL105	
136	2x	1100_6_A2_g3_G_v1	
147	4x	BN M6x10	

F - SL60, SL90, SL120, SL180

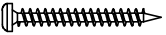

Nr:	Σ	Element:	
21	4x	DIN 125 - 8x16	
22	4x	DIN 125 - 6x12	
24	4x	ISO 7380 - M6x16	
61	2x	KL105	
136	2x	7100_5_A2_g3_G_v1	
147	4x	BN M6x10	

INST_80_2

Nr:	Σ	Element:	
1	8x	S6x60	
2	8x	W6x60	
21	8x	DIN 125 - 8x16	
146	8x	DIN 7991 - M6x12	
147	8x	BN M6x10	
148	4x	CONET ECO	



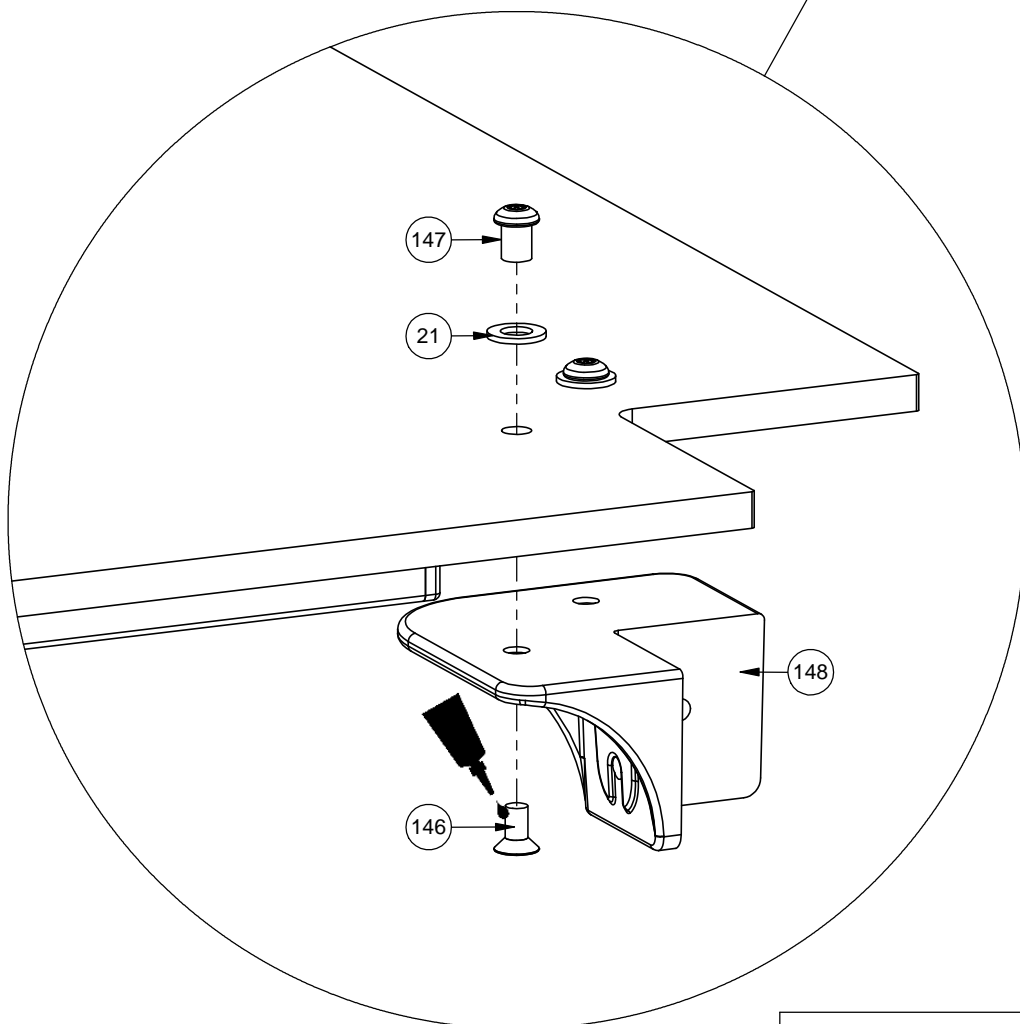
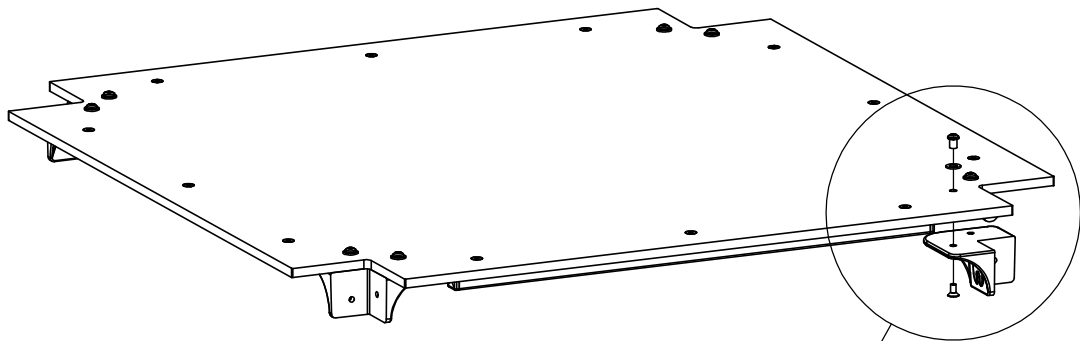

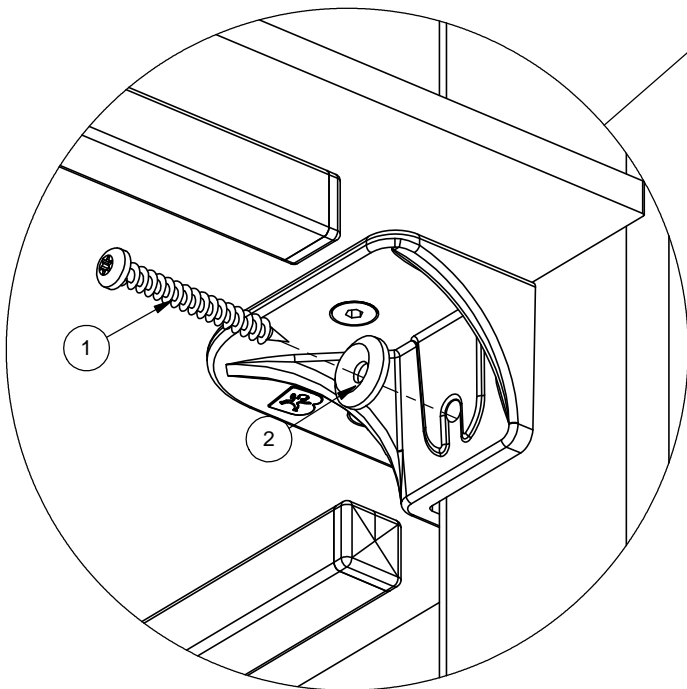
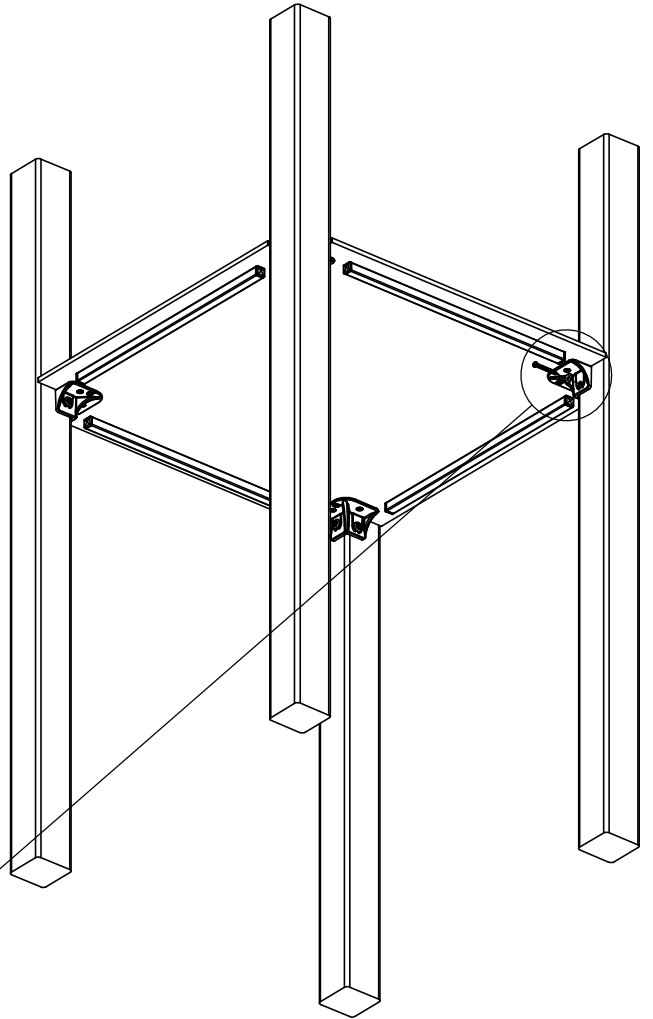
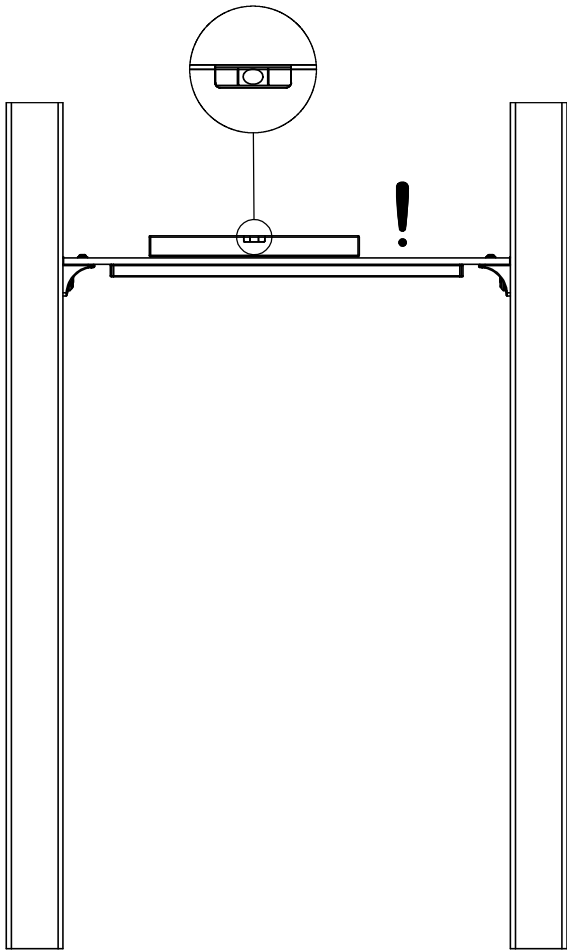

1

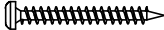

2

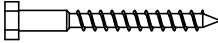

INST_80_3

Nr:	Σ	Element:	
1	7x	S6x60	
2	7x	W6x60	
16	4x	K1_d21_B	
17	4x	Z1_d21_B	
20	4x	DIN 571 - 8x80	
21	4x	DIN 125 - 8x16	

1

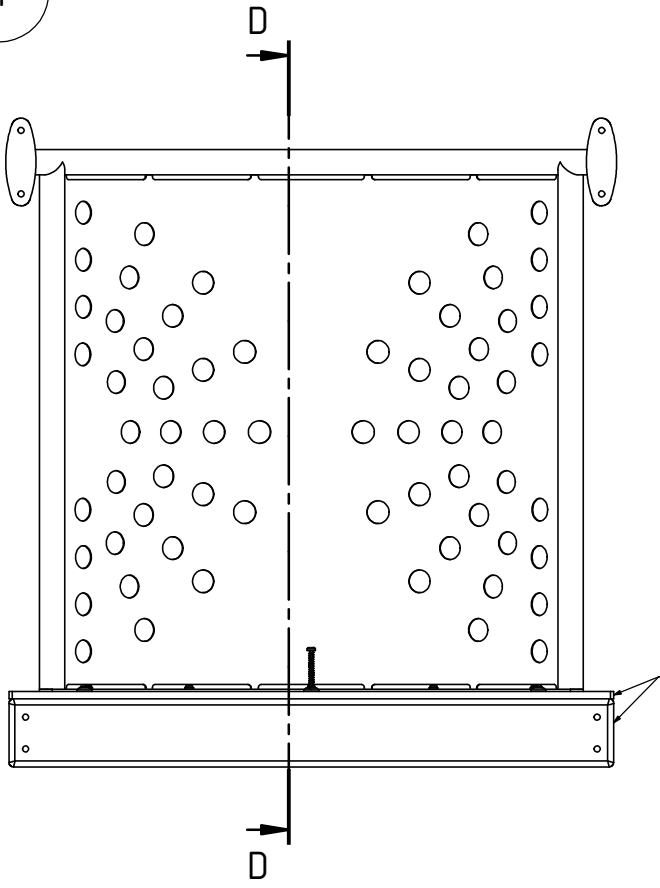

D-D (1 : 10)

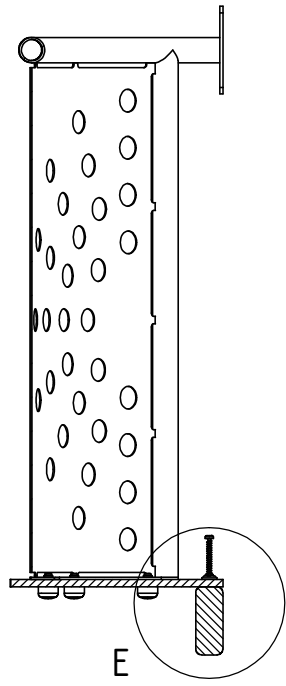

E (1 : 2)

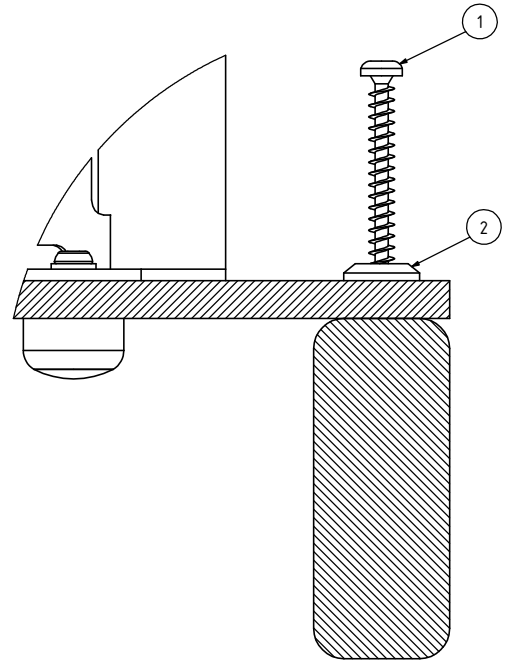

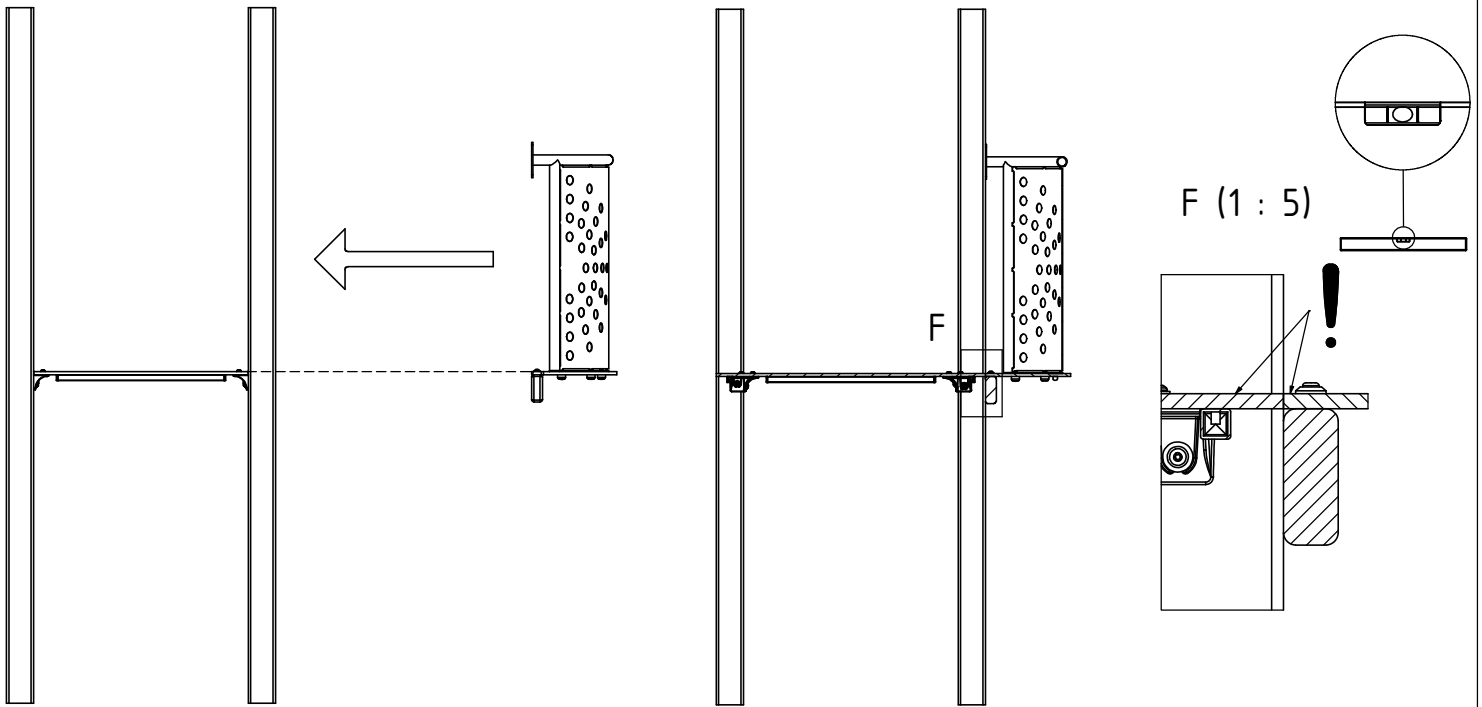

2



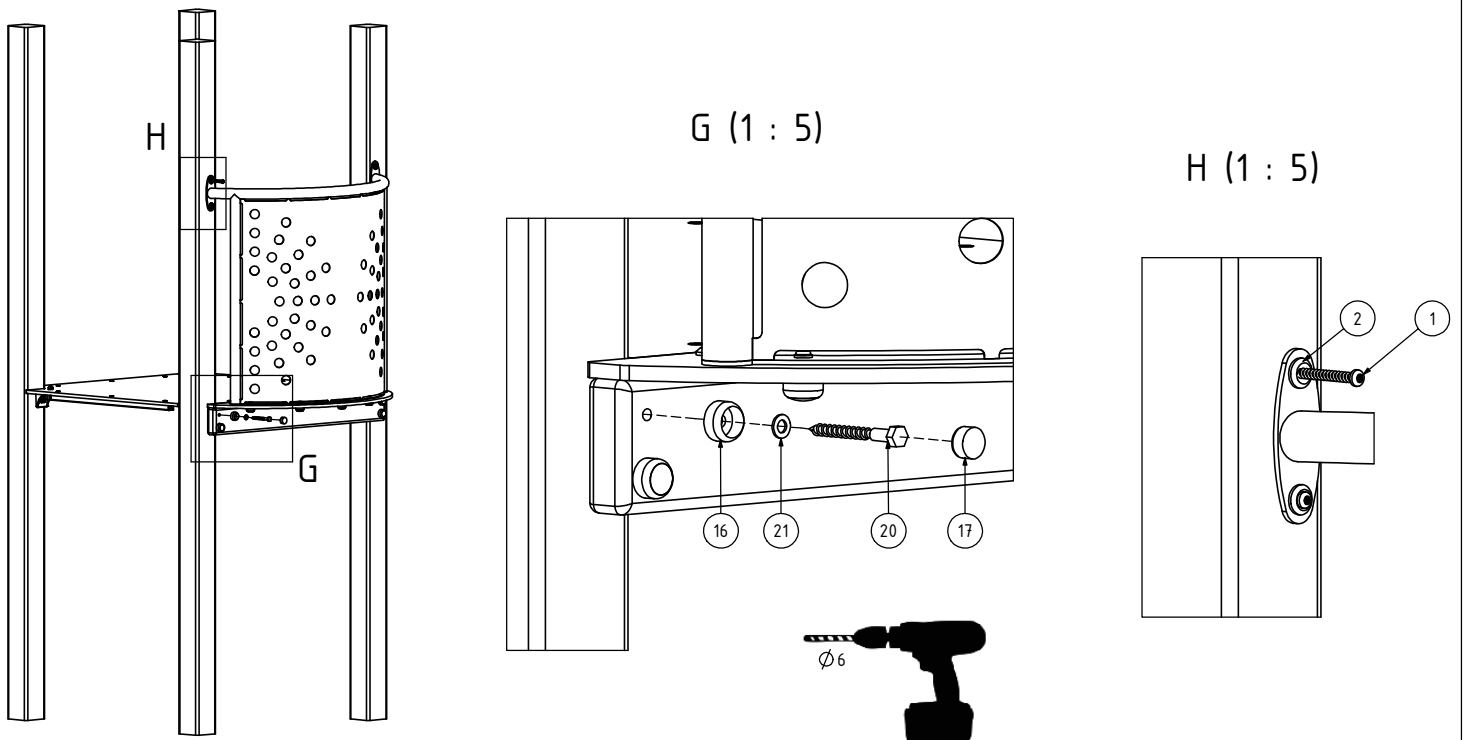

3

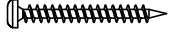

INST_80_5

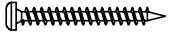

Nr:	Σ	Element:	
1	8x	S6x60	
2	8x	W6x60	

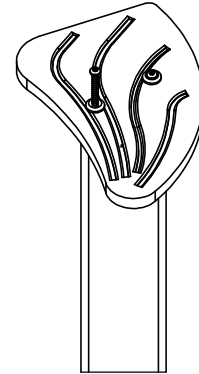
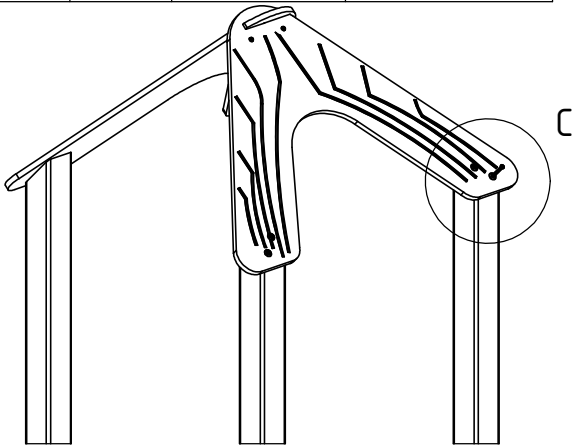
Nr:	Σ	Element:	
1	2x	S6x60	
2	2x	W6x60	



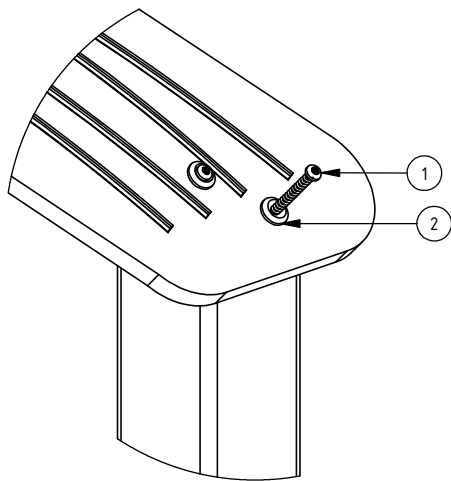

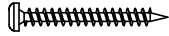
C (1 : 5)

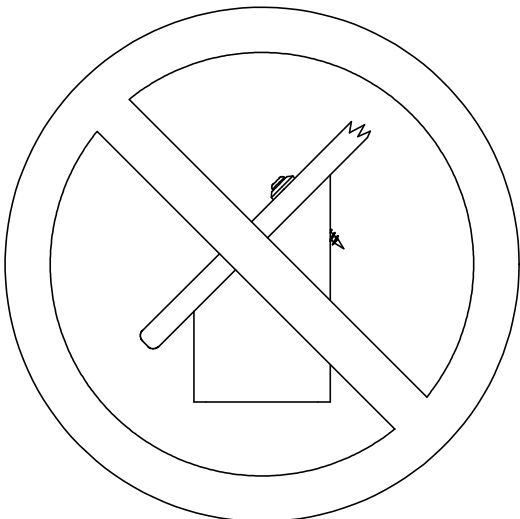
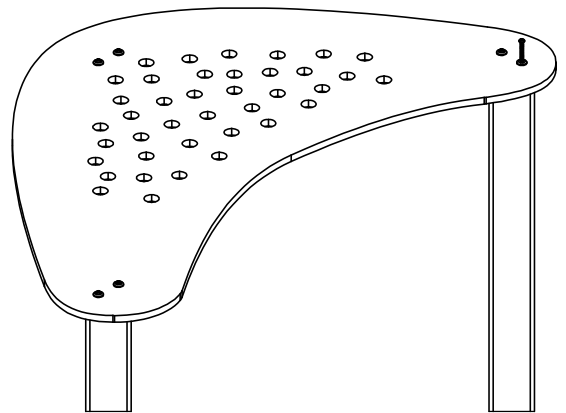

Nr:	Σ	Element:	
1	6x	S6x60	
2	6x	W6x60	

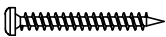

INST_80_6

Nr:	Σ	Element:	
1	4x	S6x60	
2	4x	W6x60	

N

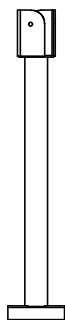



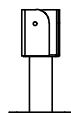

F

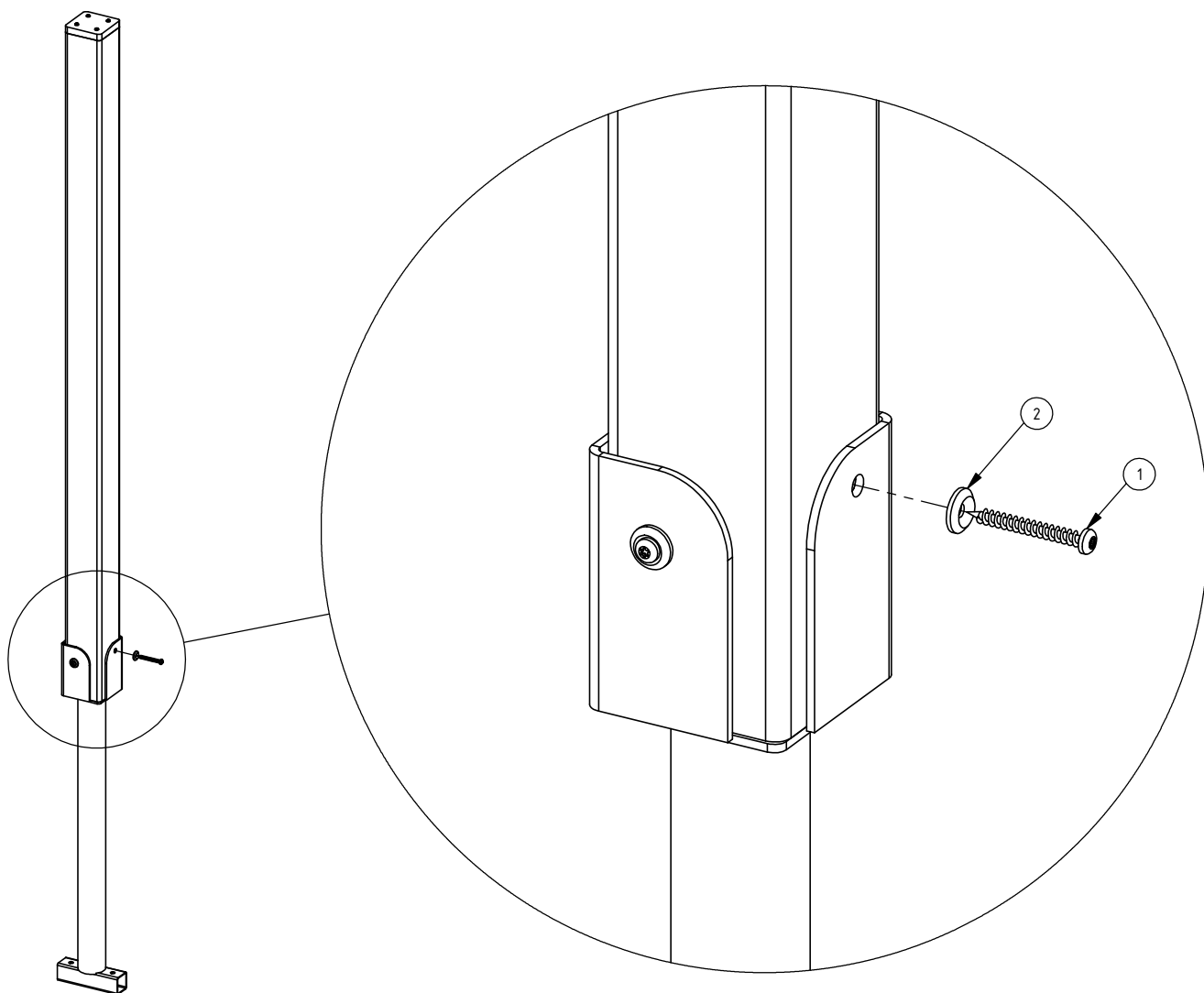

A (1 : 3)

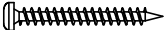

INST_80_8

Nr:	Σ	Element:	
1	22x	S6x60	
2	18x	W6x60	
21	4x	DIN 125 - 8x16	
109	4x	DIN913 M10x10	
149	2x	ALUZ SD	

1

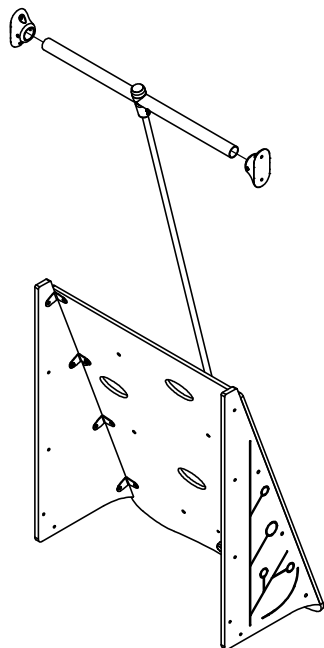

2

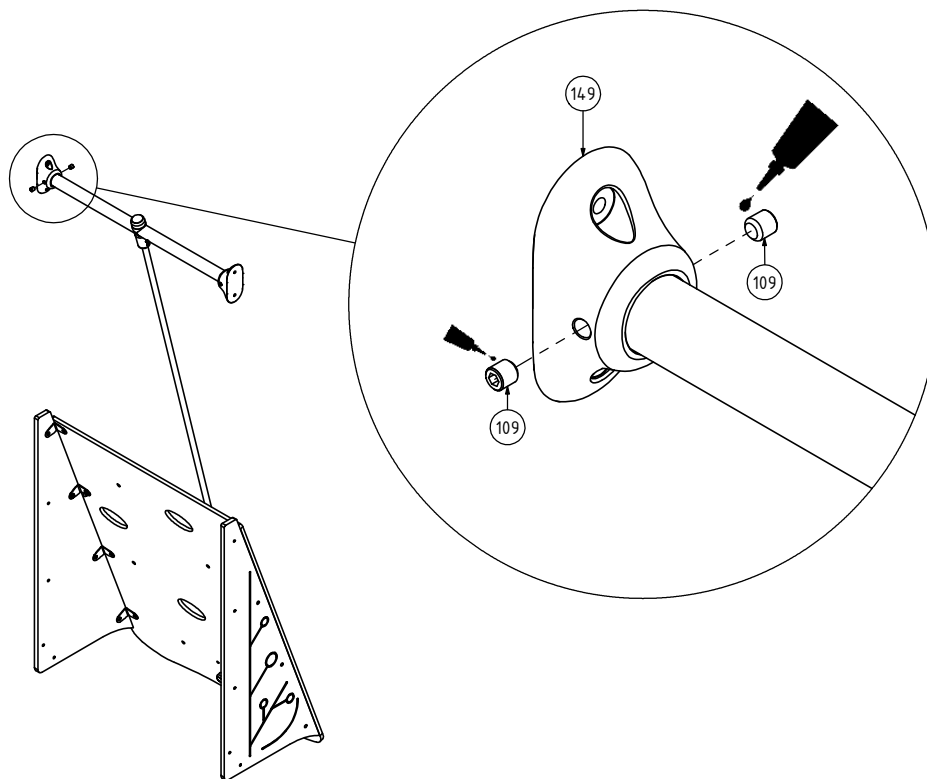

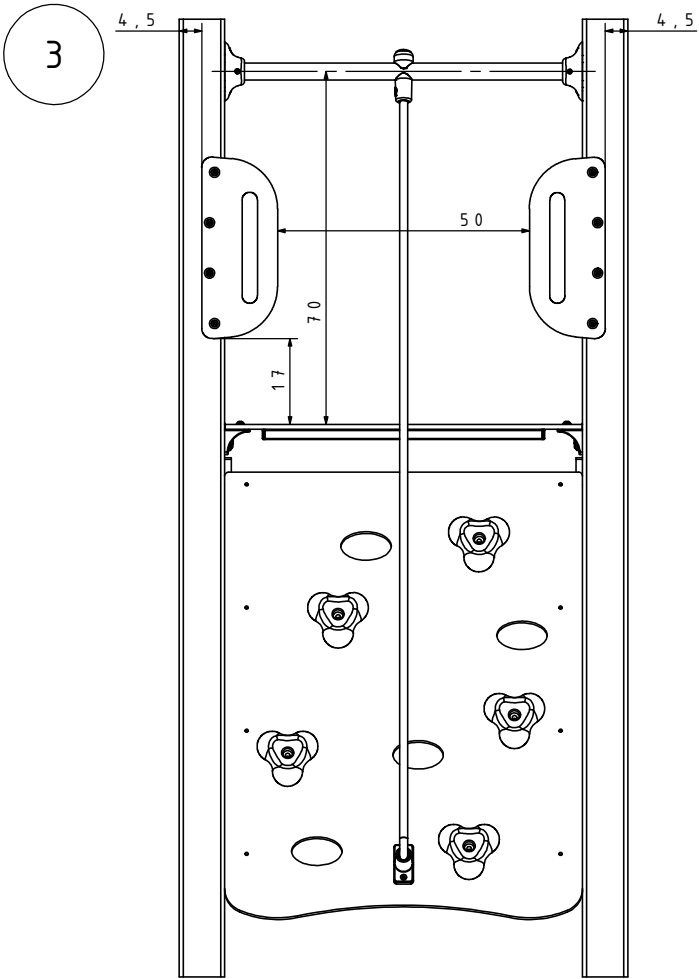

D (1 : 3)

E (1 : 3)

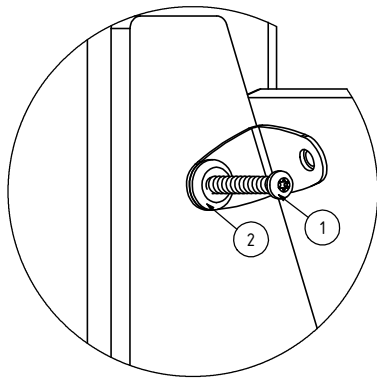
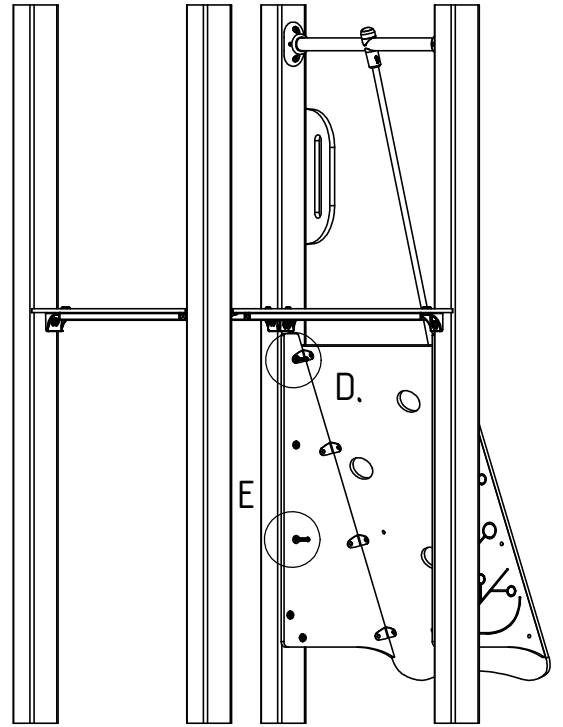



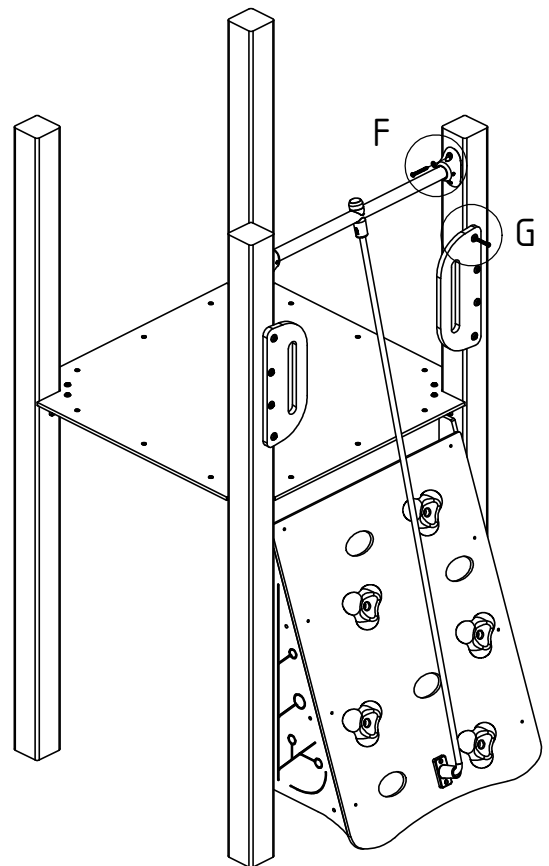
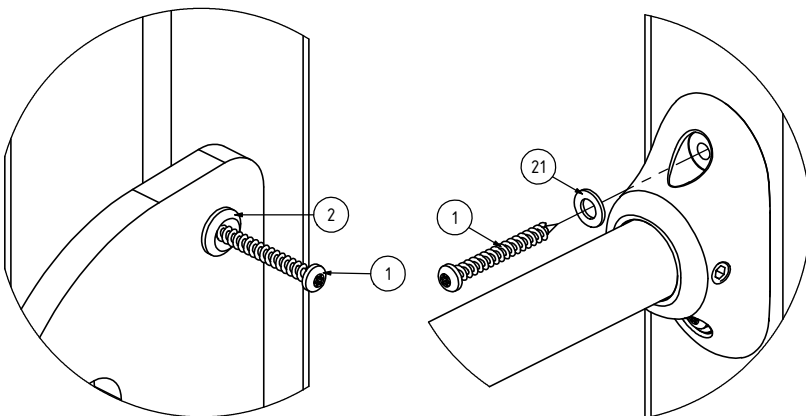

G (1 : 3)

F (1 : 3)

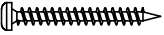

INST_80_14

Nr:	Σ	Element:	
1	16x	S6x60	
2	8x	W6x60	
21	8x	DIN 125 - 8x16	
109	8x	DIN 913 10x10	
149	4x	ALUZ SD	

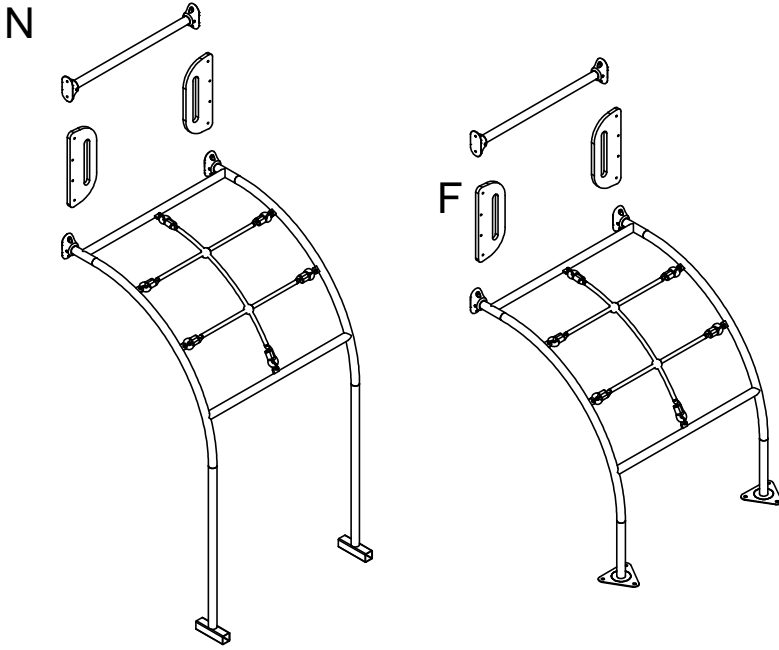

1

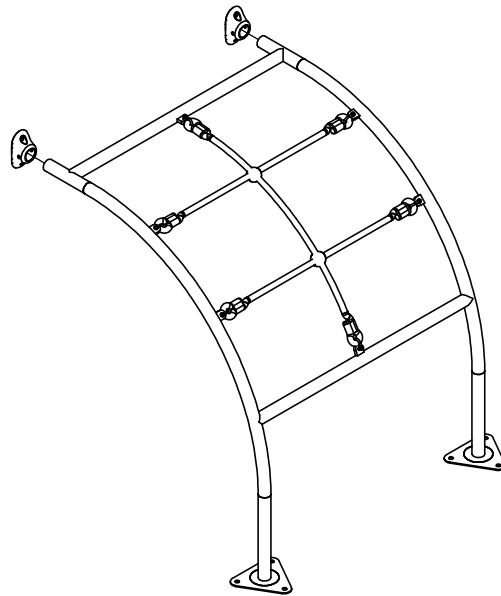

2

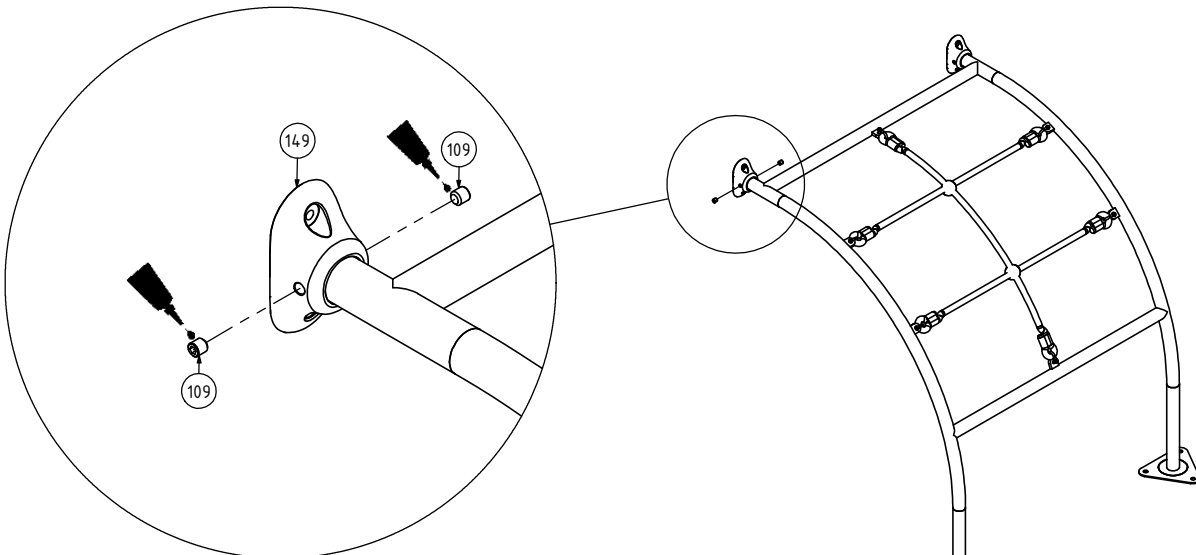

3

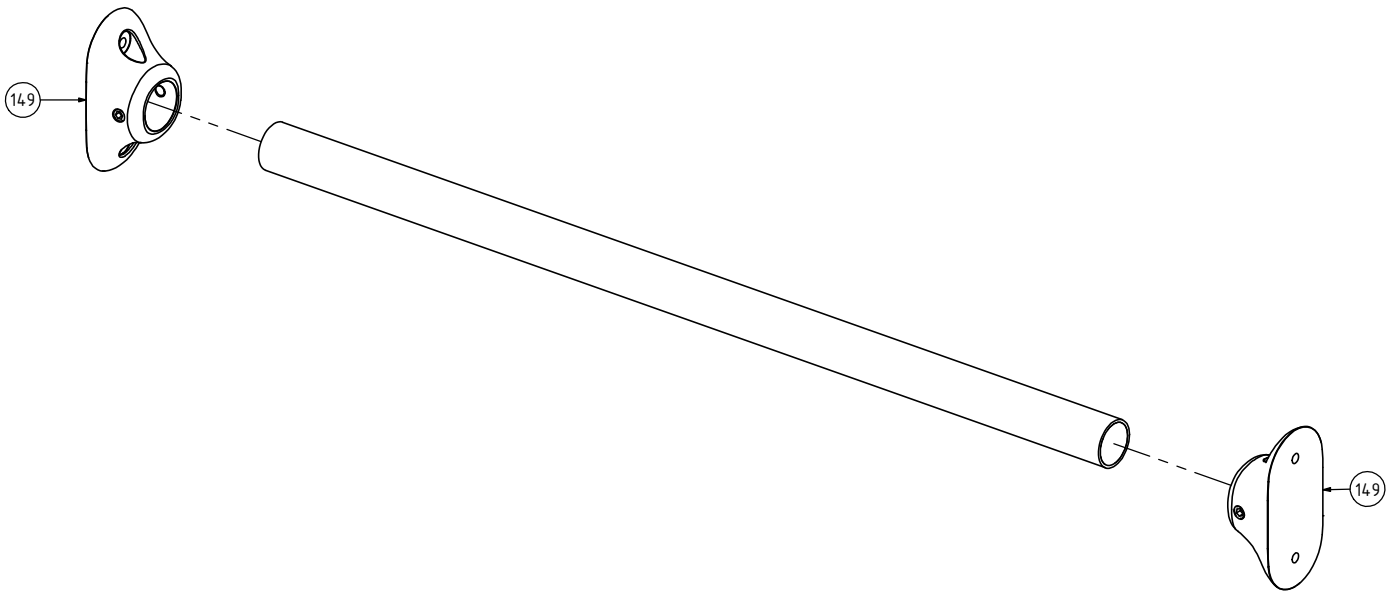

4

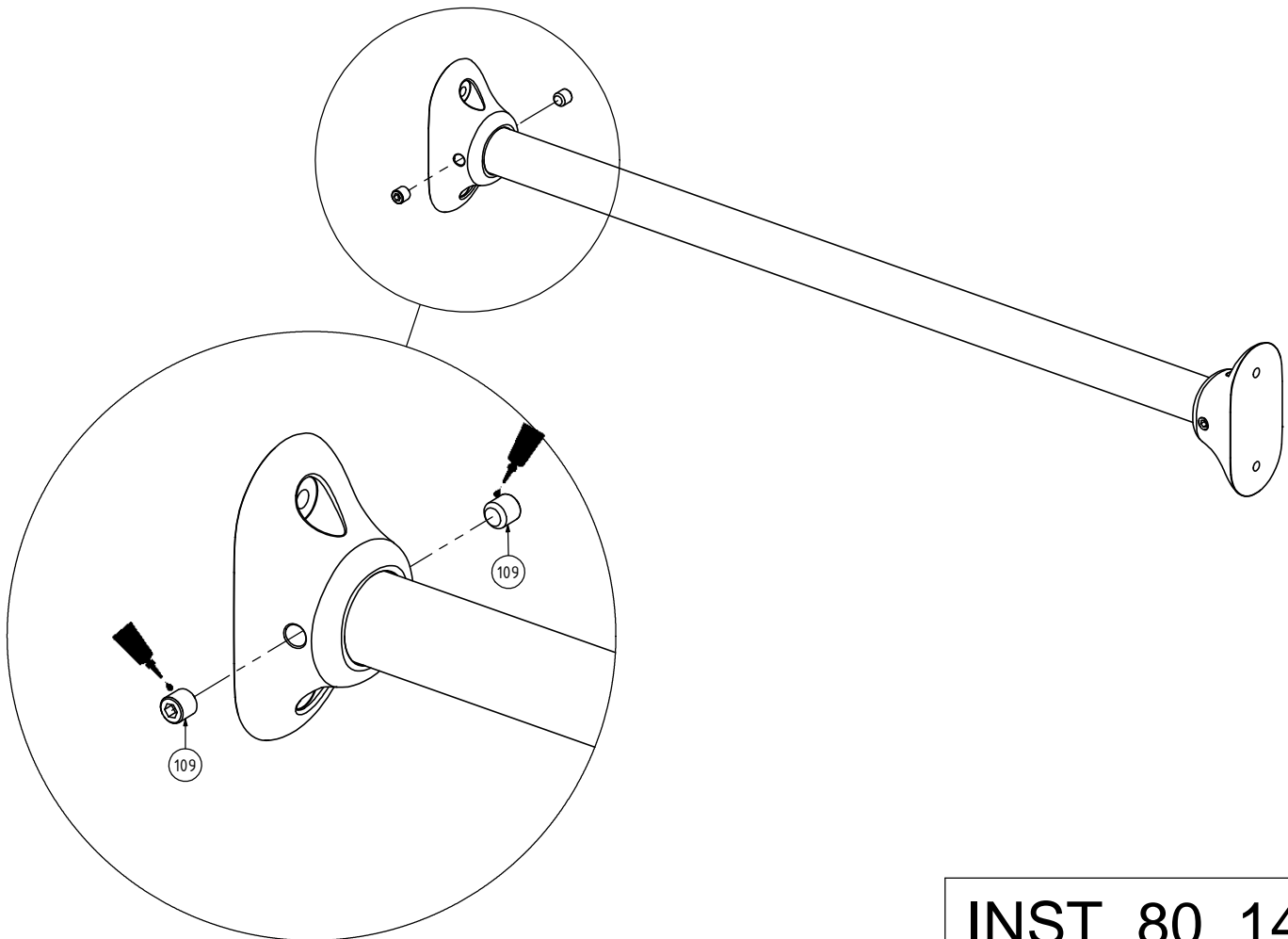

5

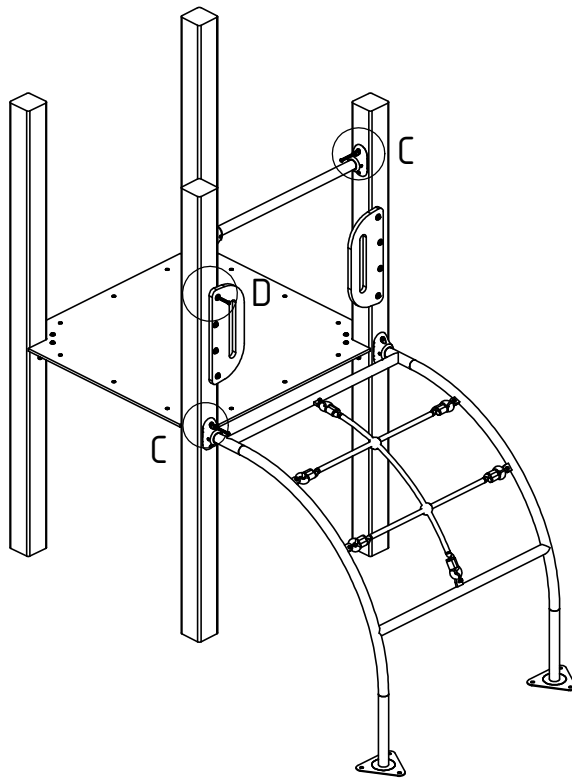

C (1 : 3)

D (1 : 3)

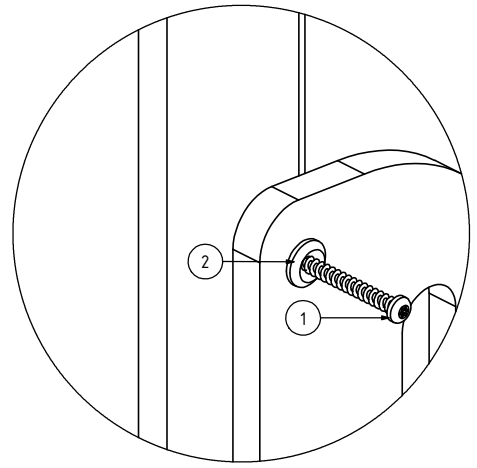
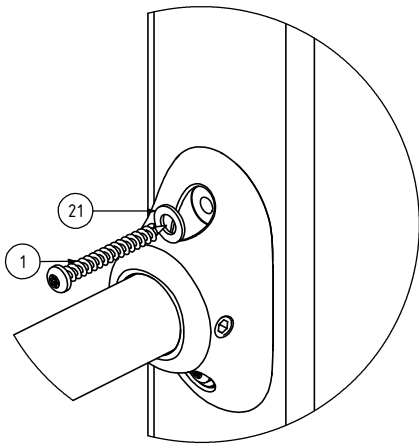



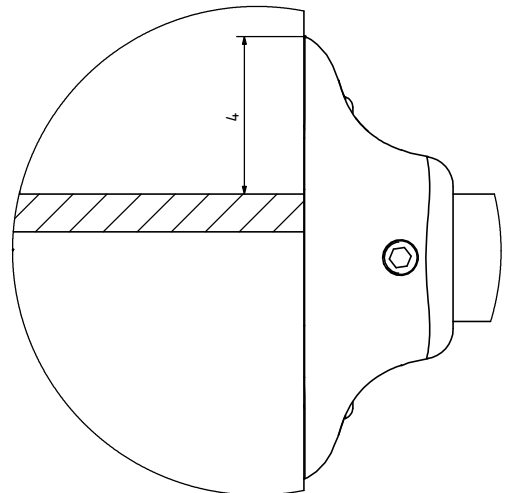
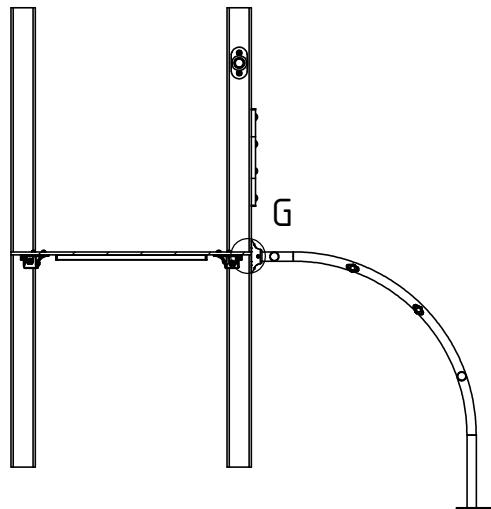
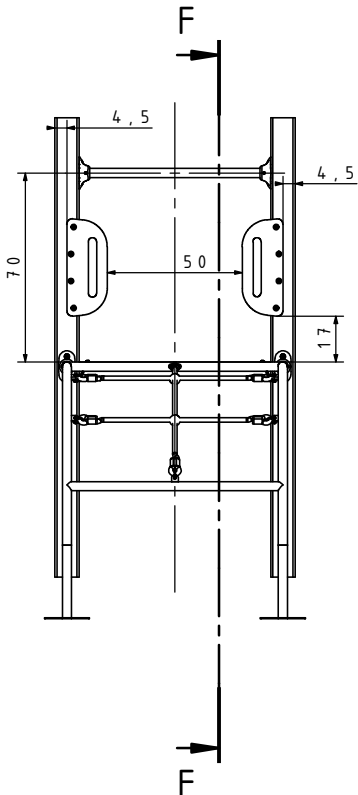

F-F (1 : 28)

G (1 : 2)

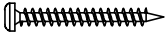

INST_80_15

Nr:	Σ	Element:	
1	12x	S6x60	
2	8x	W6x60	
21	4x	DIN 125 - 8x16	
109	4x	DIN 913 10x10	
149	2x	ALUZ SD	

N

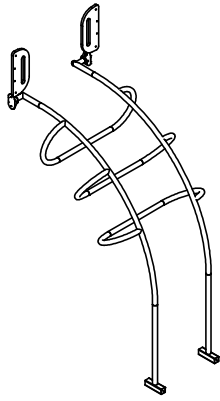

F

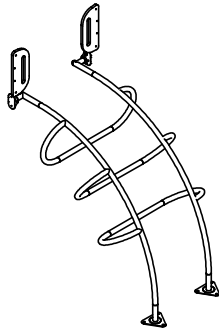

1

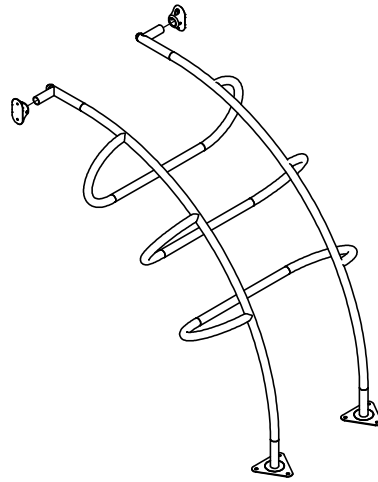

2

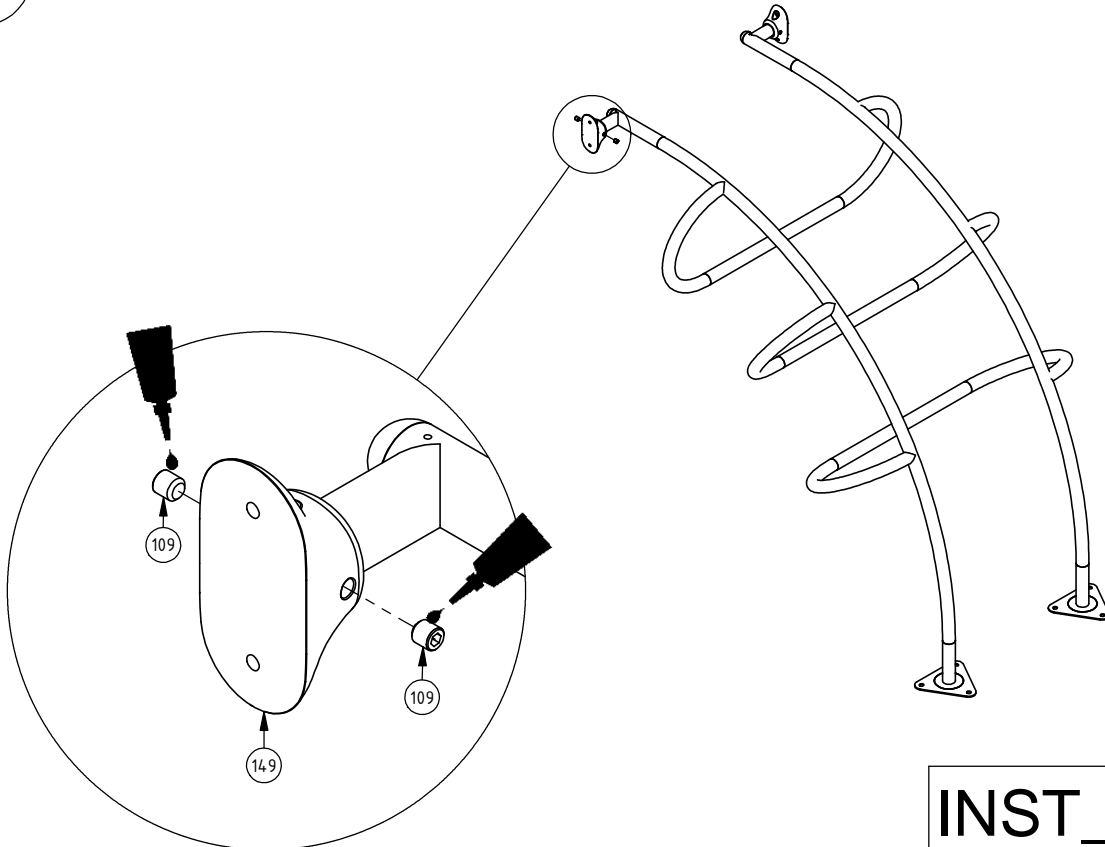

3

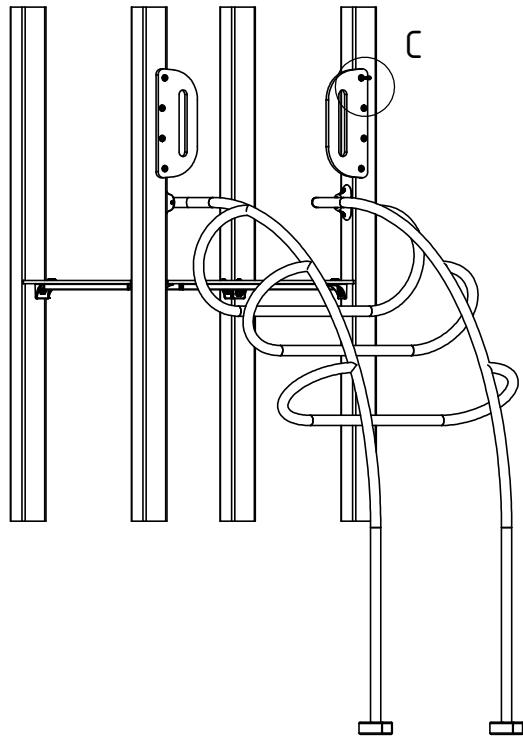
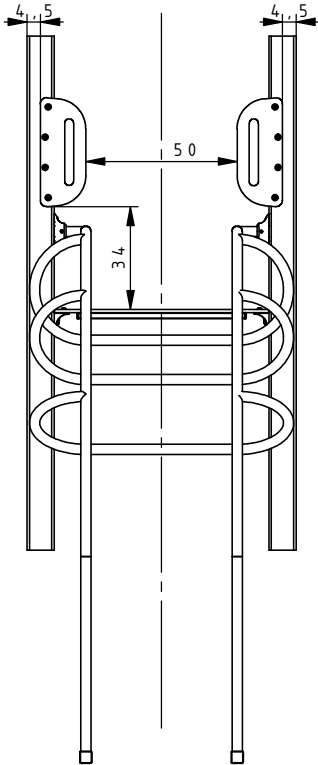

C (1 : 3)

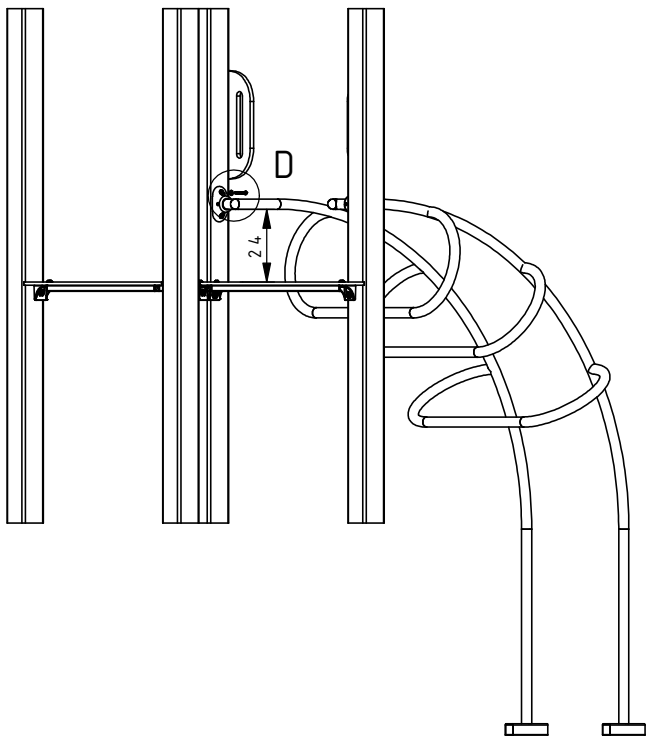
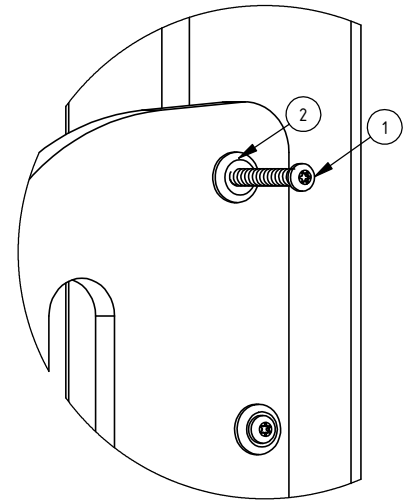



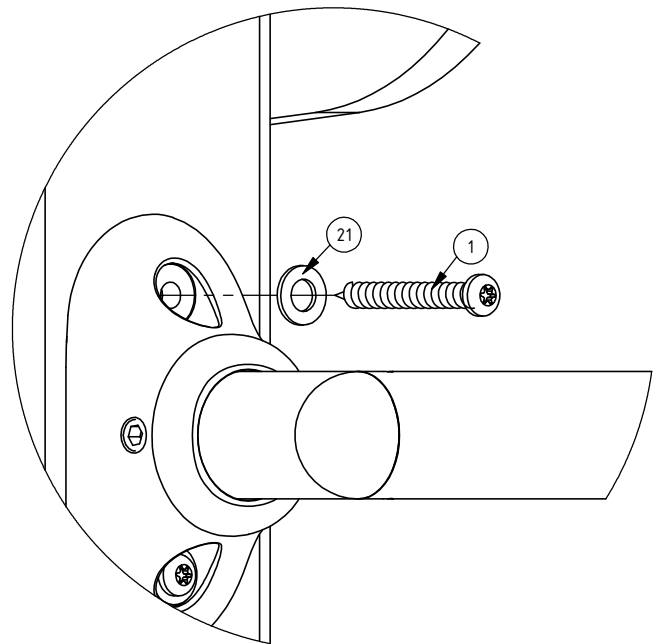

D (1 : 2)

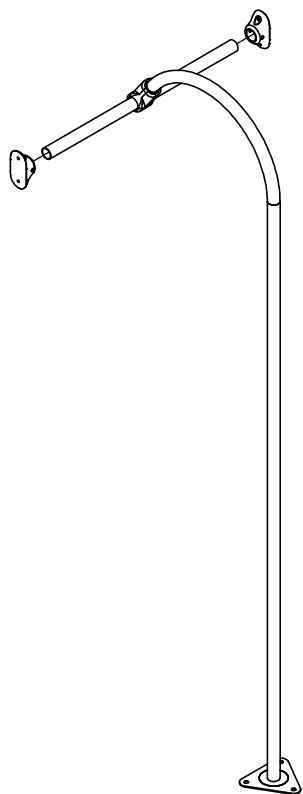

INST_80_16

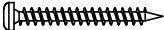
1



Nr:	Σ	Element:	
1	12x	S6x60	
2	8x	W6x60	
21	4x	DIN 125 - 8x16	
109	4x	DIN913 M10x10	
149	2x	ALUZ SD	

N

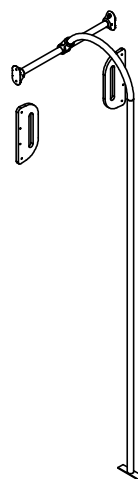

F

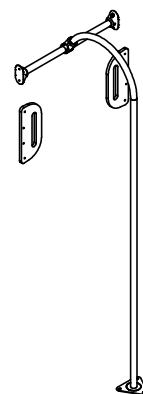



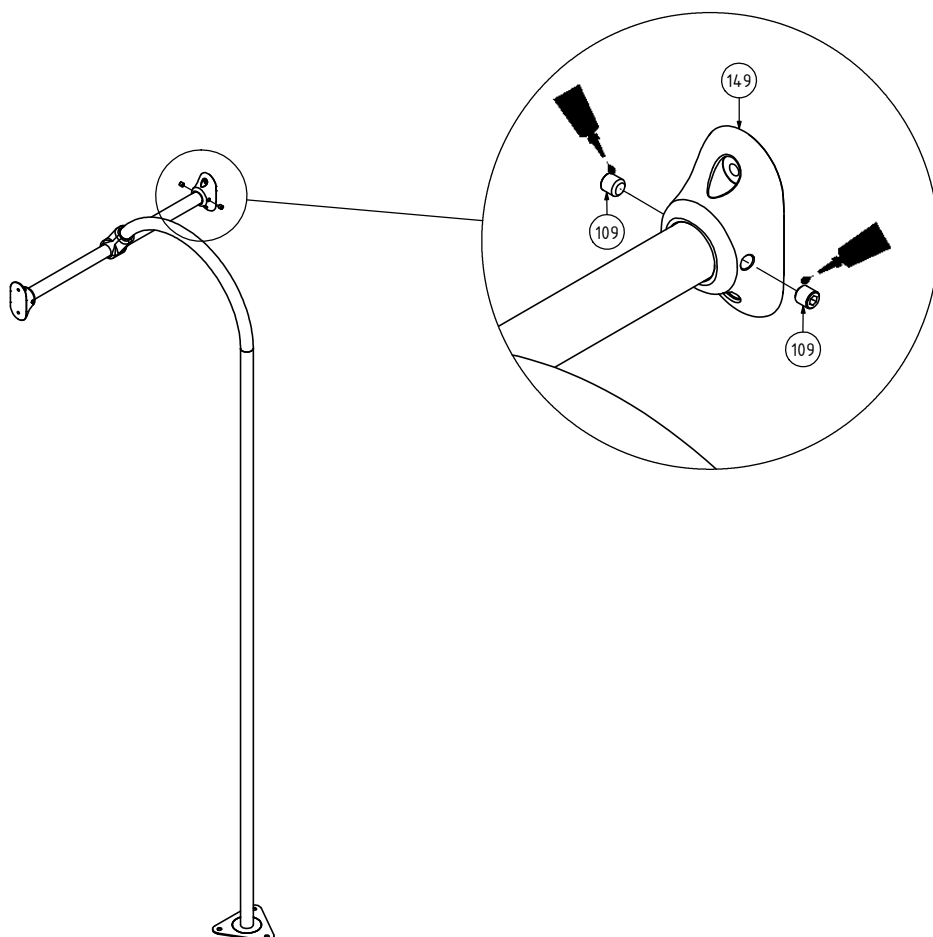

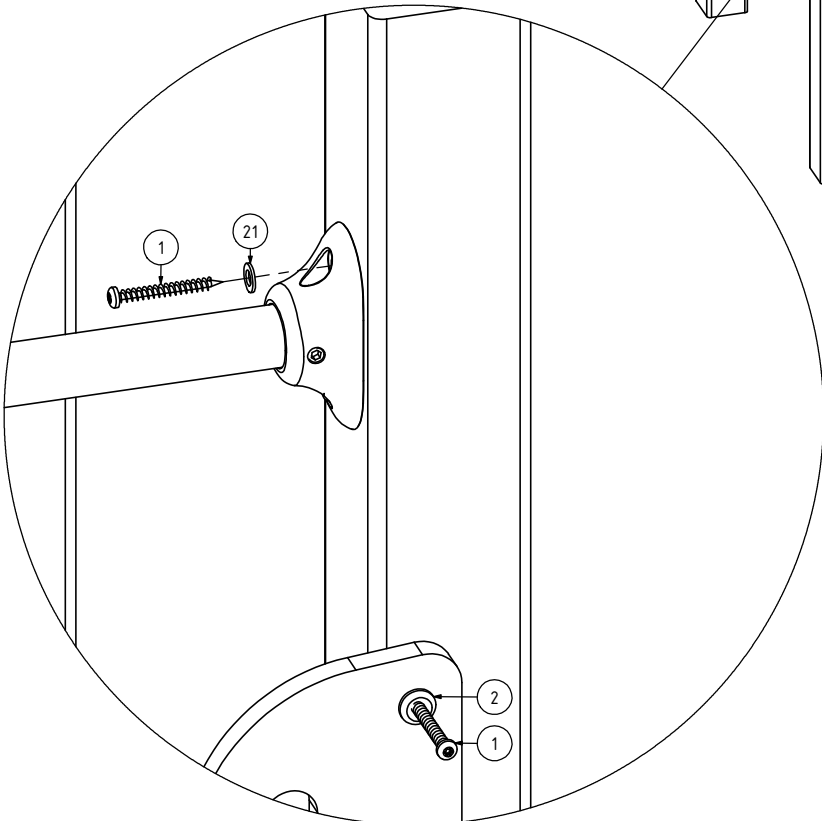
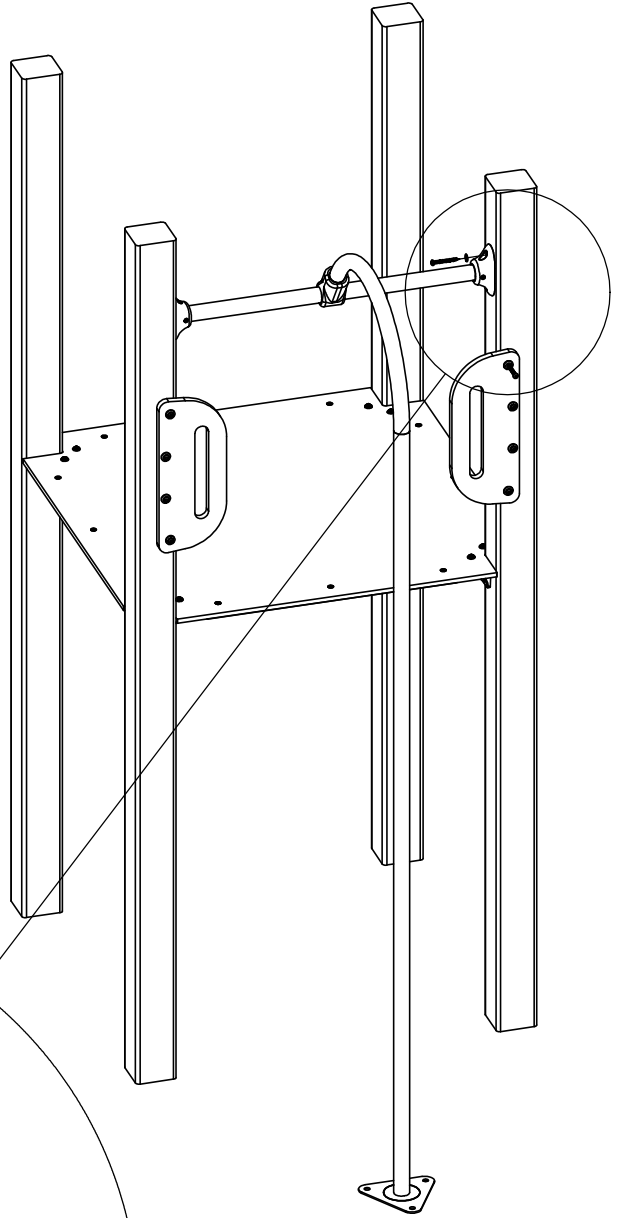
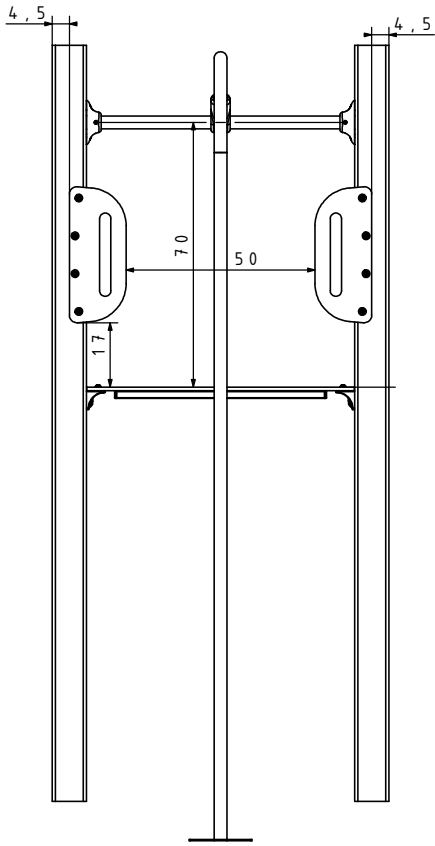

2

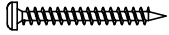

3



INST_80_19

Nr:	Σ	Element:	
1	20x	S6x60	
2	20x	W6x60	
9	40x	ISO 7380 - M6x25	
21	40x	DIN 125 - 8x16	
22	40x	DIN 125 - 6x12	
14.7	40x	BN M6x10	

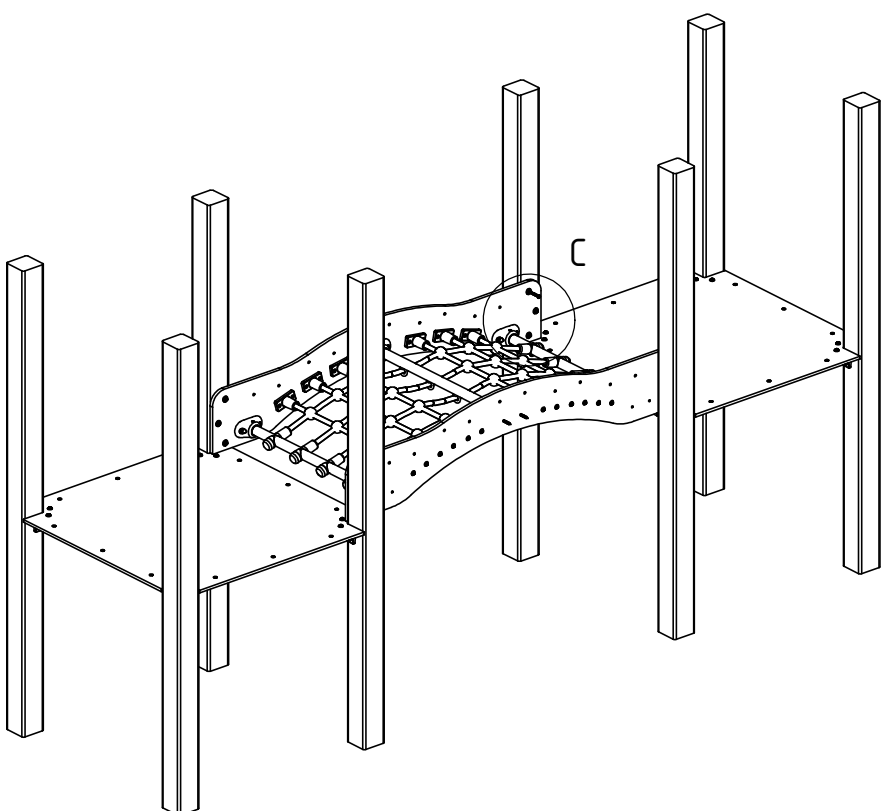

C (1 : 3)

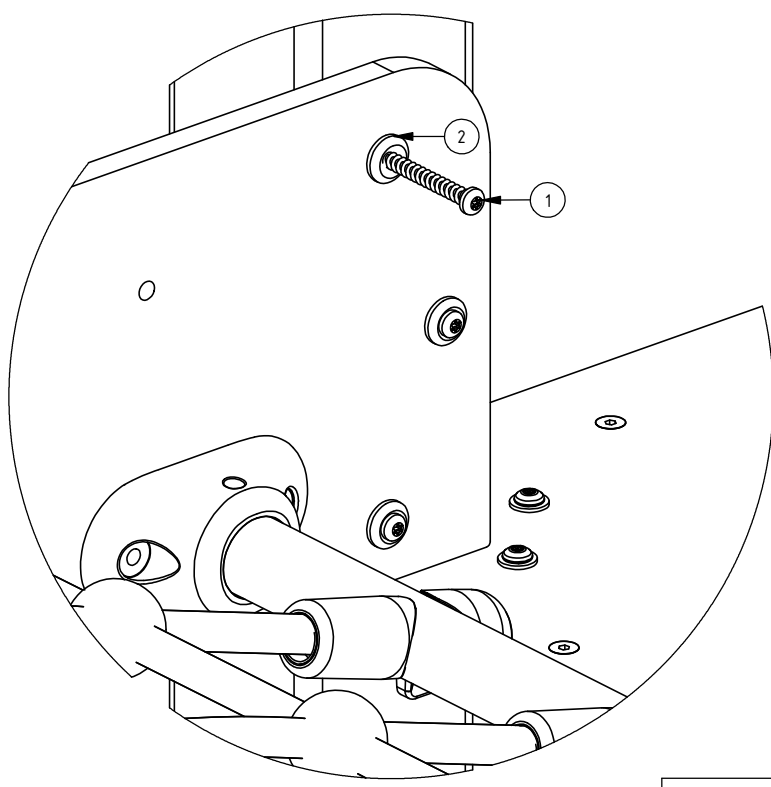

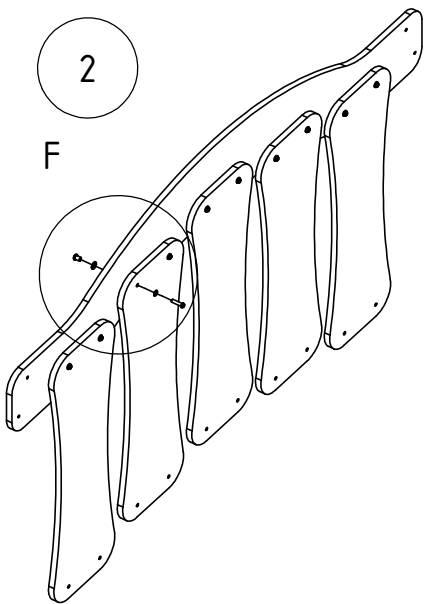

F (1 : 4.5)

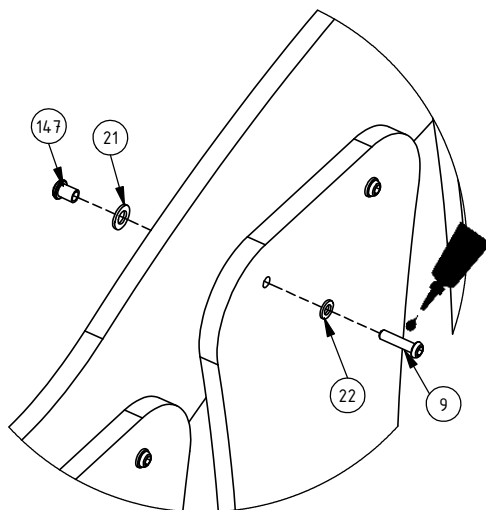

3

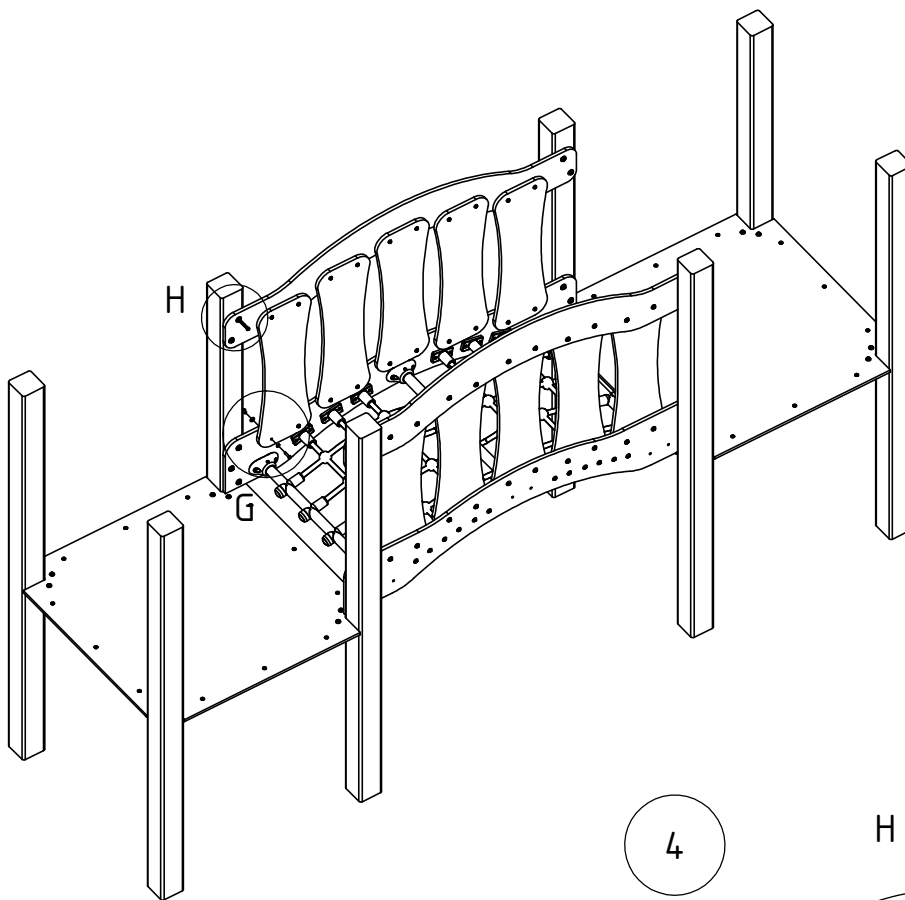



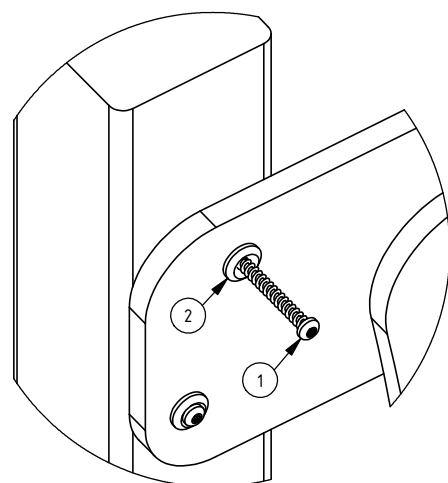
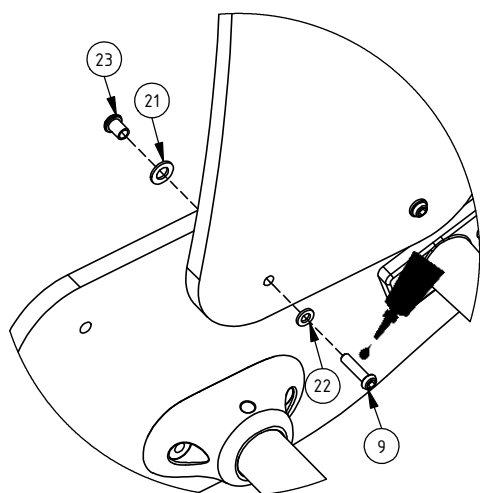

4

H (1 : 3.5)

G (1 : 4.5)

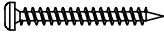



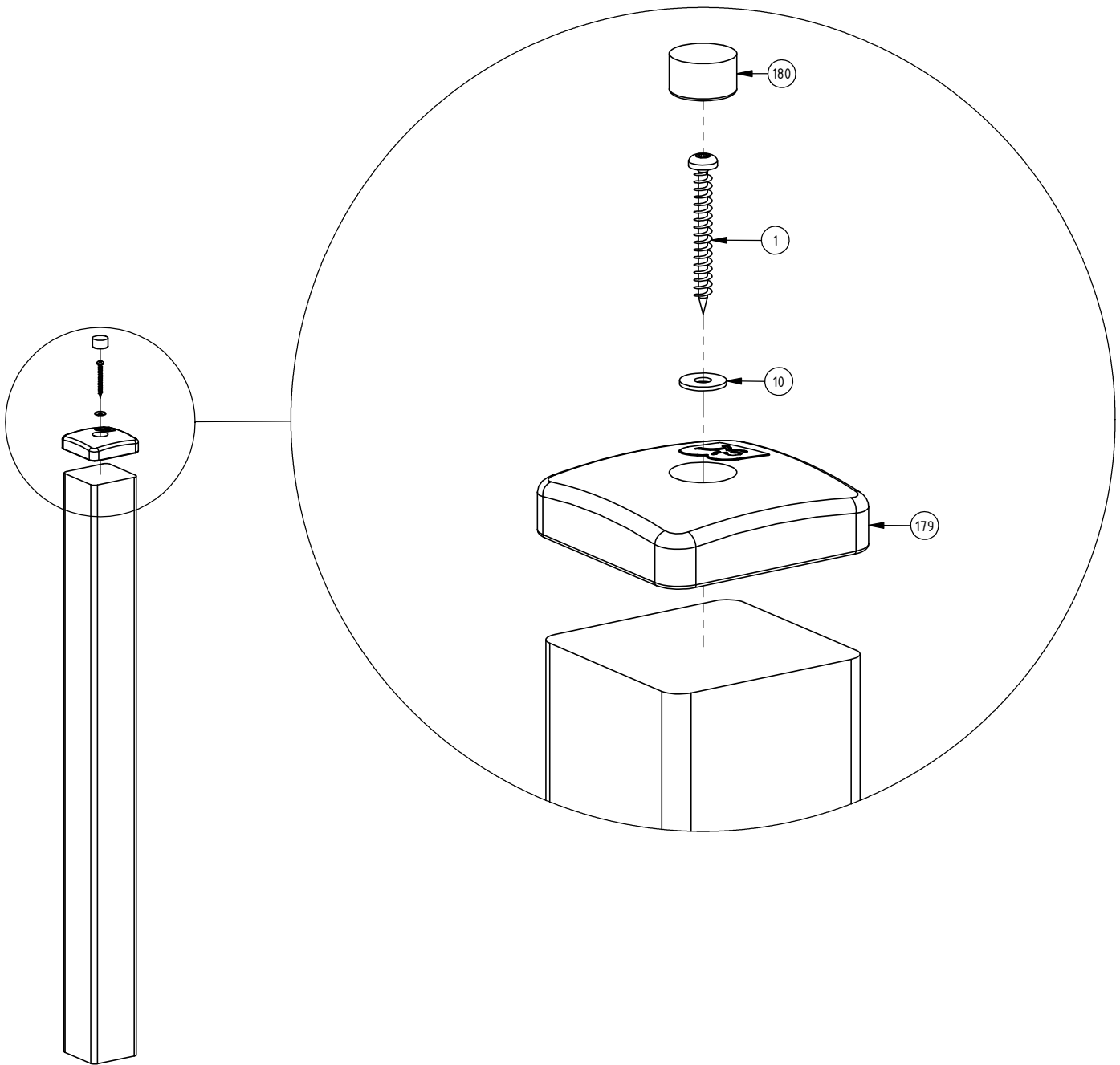

INST_80_44

Nr	Σ	Element		
1	1		-	S6x60
10	1		DIN 9021	6x18
179	1		-	Z_ECO_1
180	1		-	K_ECO_1

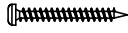

INST_Z_3

Nr	Σ	Element		
1	1		-	S6x60
3	1		-	K2_d30_B
21	1		DIN 125	8x16
213	1		-	Z_NA_1
214	1		-	Z_NA_2

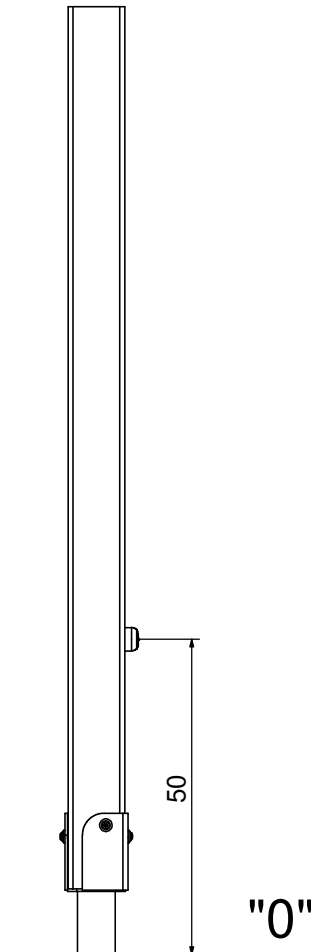
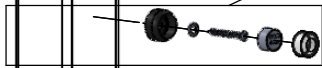
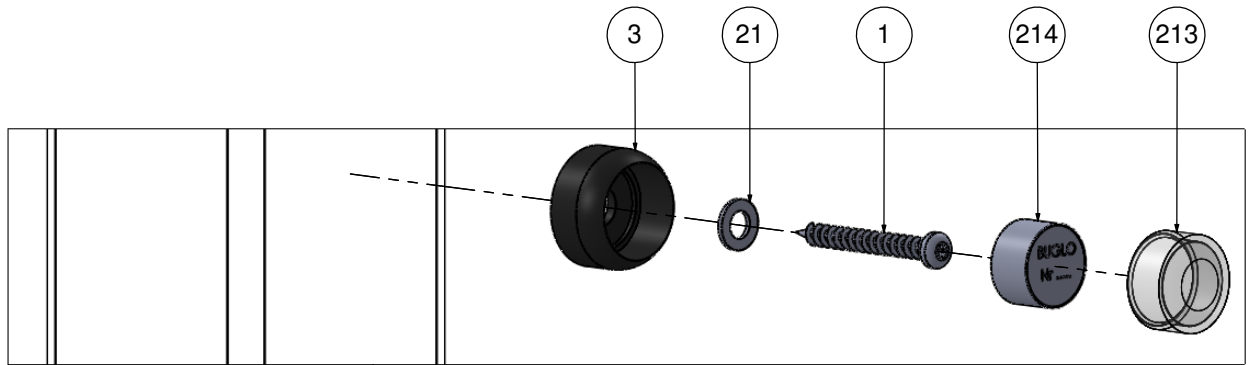
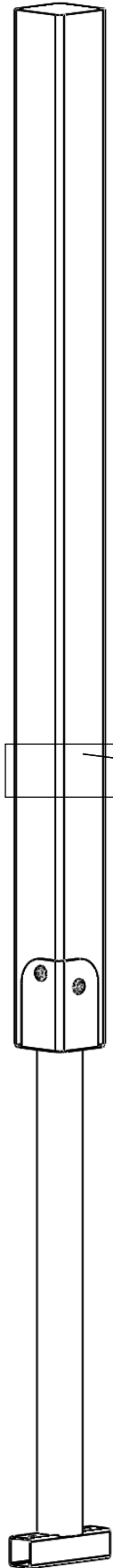

Tuotteen huolto-ohje

Leikkikenttävälineemme täyttävät EN-1176-1 : 2017- 12 -standardin turvallisuusvaatimukset.

On suotavaa ottaa yhteyttä tuotteen valmistajaan liittyen takuun alla olevien osien huoltotöihin. Vahingoittuneet maalipinnat tulee puhdistaa pölystä, rasvasta ja ruosteesta. Tämän jälkeen puhdistettu pinta tulee peittää ruostumattomalla pohjamaalilla ja sitten maalata kahdesti teräspinoille tarkoitetulla maalilla.

LeikkiSet Oy:n käyttämät väriyhdistelmät:

- 1) Harmaa - RAL 7035
- 2) Keltainen - RAL 1003
- 3) Sininen - RAL 5015
- 4) Punainen - RAL 3000
- 5) Vihreä - RAL 6018
- 6) Musta - RAL 9005
- 7) Violetti - RAL 4008
- 8) Antrasiitti - RAL 7016
- 9) Hopea - RAL 9006
- 10) Beige - RAL 1019
- 11) Oranssi - RAL 2009

Puu vaatii säännöllistä huolenpitoa. Ilmasto-olosuhteista, käyttöasteesta ja mekaanisista vaurioista riippuen on suositeltavaa uudistaa kyllästyskerros 2 - 5 vuoden kuluttua.

Suosittellemme käyttämään tuotteita: GORI 356 puunsuoja-ainetta ja NORDICA EKO 3330-12-BASE T pintamaalia (väri 1806), nämä löydät sivustolta www.teknos.com.

Suosittelavaa on, että osat jotka ovat ruostumatonta terästä puhdistetaan kerran vuodessa, jotta epäpuhtaudet eivät aiheuta värimuutoksia teräkseen. Pese puuvillaliinoilla ja veteen liuotetulla miedolla pesuaineella, esim. astianpesuaine. Puhdistuksen jälkeen huuhtelee vedellä ja pyyhi kuivaksi.

HUOMIO! Ruostumattoman teräksen puhdistukseen käytettävät puhdistusaineet eivät saa sisältää: klooria, suolaa, happoja tai valkaisuaineita. Jo pieni määrä näitä aineita voi aiheuttaa kromioksidipinnan pysyviä vaurioita

- 1) Kausittainen tarkastus - kun väline on aktiivisessa käytössä, tulee sen kunto tarkastaa viikoittain tai useammin. Samalla tulee tarkistaa mahdolliset välineeseen kohdistuneet ilkeivät teot.

Kausittainen tarkastus pitää sisällään:

- Rakenteiden vakauden tarkistaminen
- Yleinen tarkastus osien puuttumisen varalta
- Tarkistaminen halkeamien, terävien reunojen ja muiden vaurioiden varalta
- Välineen ympäristön siisteys
- Mahdollisen turva-alustan kunnon tarkistaminen

- 2) Välineen sisäinen valvonta - tulee suorittaa kerran kolmessa kuukaudessa. Se pitää sisällään yleistarkastuksen, minkä lisäksi tulee tarkistaa myös välineen toiminnot.

Sisäinen valvonta pitää sisällään:

- Mahdollisen turva-alueen pinnan tarkistaminen ja mittaaminen (jos pinta on yli 10cm alle oikean tason, pitää sitä täydentää)
- Kaikki ruuvit ja mahdolliset kaapelit sekä verkot tulee kiristää

3) Vuositarkastus (pakollinen)

- Rakenteiden vakauden tarkistaminen
- Mahdollisten ruostevaurioiden tarkastaminen ja korjaaminen
- Perustusten tarkistaminen
- Mahdollisen turva-alueen pinnan tarkistaminen ja mittaaminen (Jos pinta on yli 10cm alle oikean tason, pitää sitä täydentää)

Kaikilla laitteilla on oltava säännöllinen tarkastusvalvonta. Tarkastuksen tekijän tulee kirjata tiedot tarkastuksesta ylös.