

1114 Kiipeilykeskus asennusohje

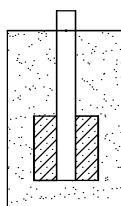

114N
betoni

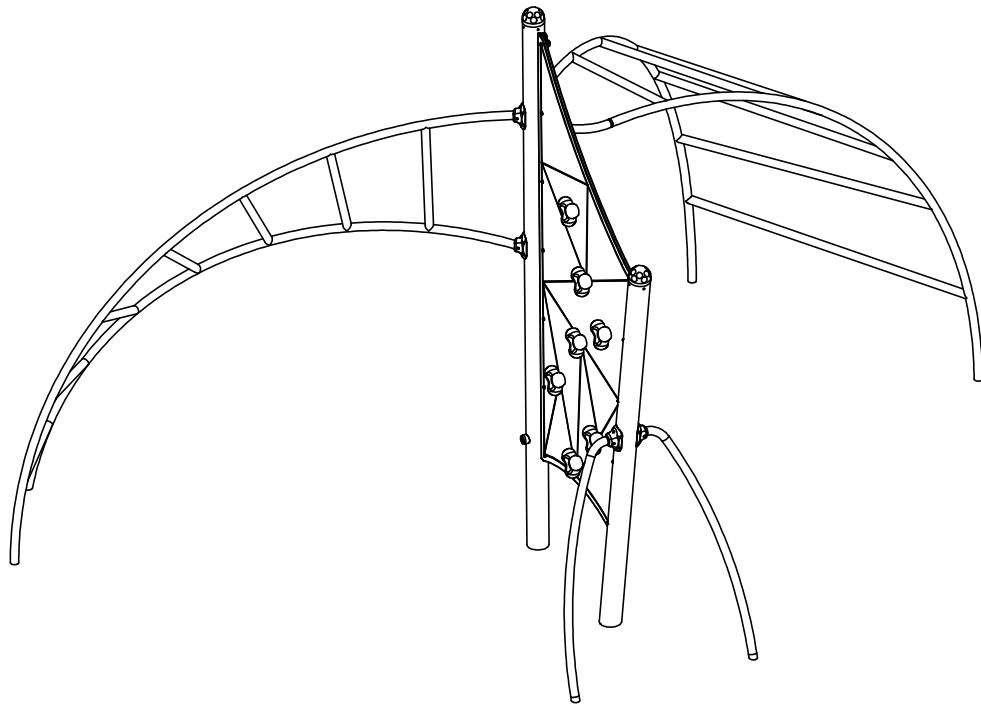
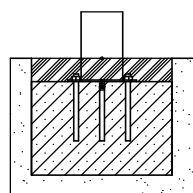

114F
pinta

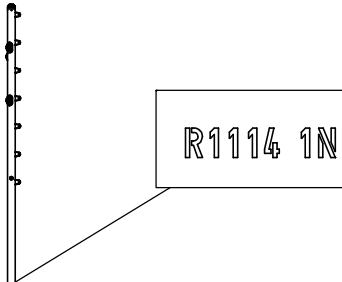
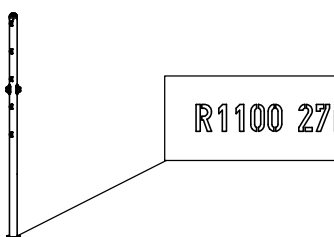
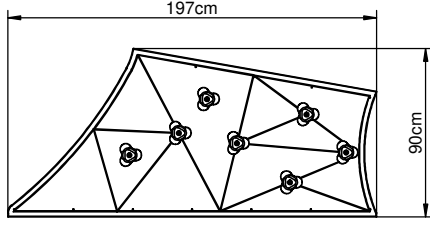
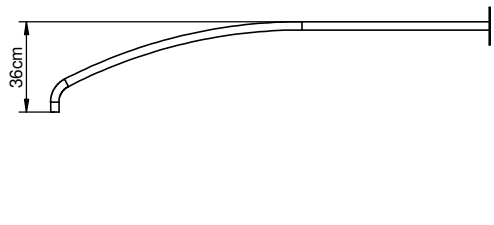
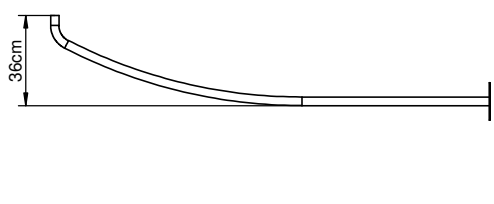
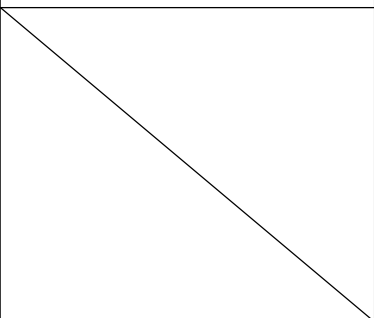
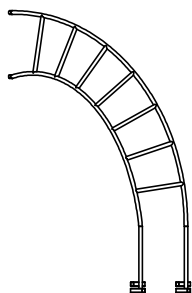

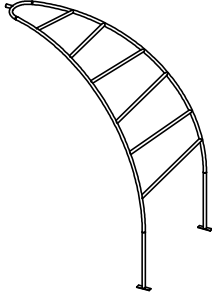
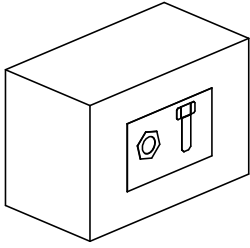

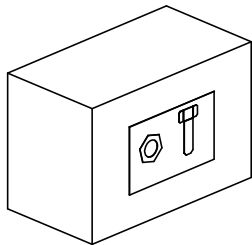



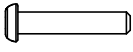

NR	ELEMENT	1114N	1114F
E1		1	1
E2		1	1
E3	 <p data-bbox="239 1198 454 1232">F1W_7_HP_g13_v1</p>	1	1
E4		2	1
E5			1
E6		1	1

NR	ELEMENT	1114N	1114F
E7		1	1
E8		1	1



1114N

1114F

Nr	Element	DIN	ELEMENT	Σ	Σ
10		DIN 9021	6x18	12	12
15		ISO 7380	M6x30	12	12
16		-	K1_d21_B	12	12
17		-	Z1_d21_B	12	12
18		DIN 985	M6	12	12
22		DIN 125	6x12	12	12
58		-	LIIMA	1	1
61		-	KL105		12
109		DIN 913	10x10	2	2
213		-	Z_NA_1	1	1
214		-	Z_NA_2	1	1

1114N
1114F

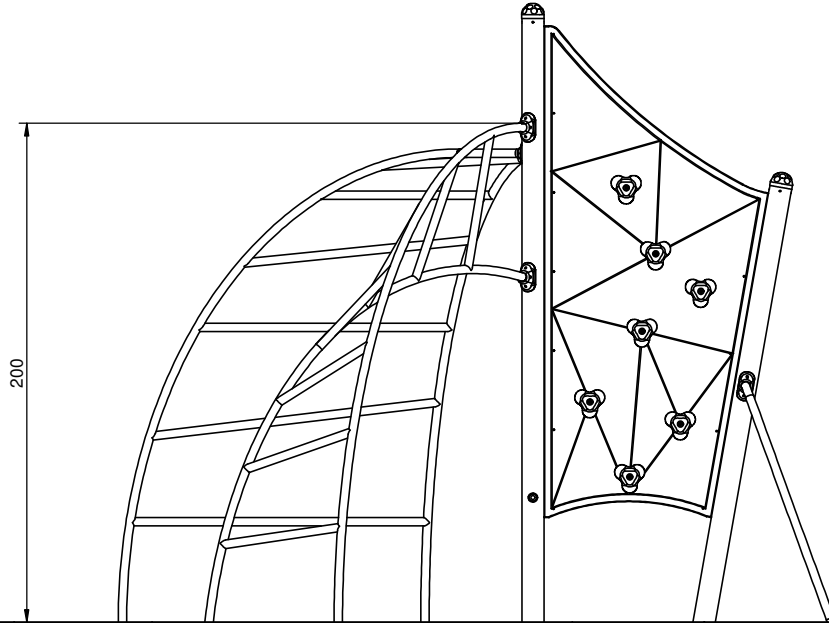

"0"

1114N
1114F

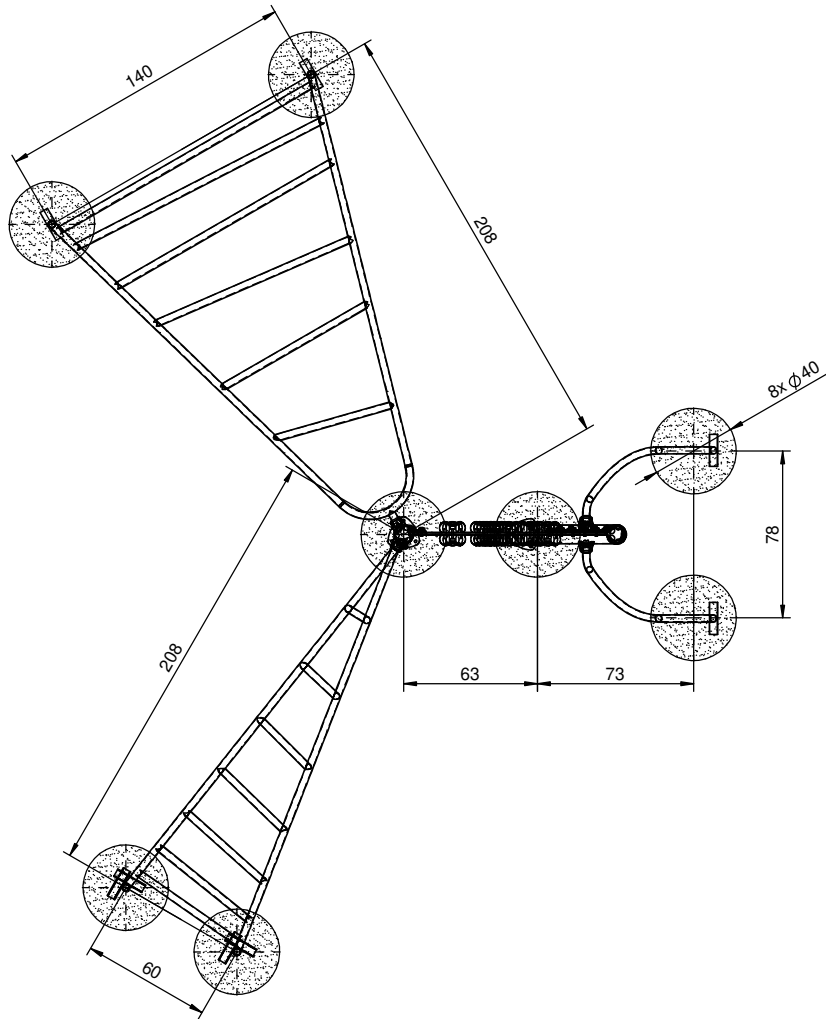
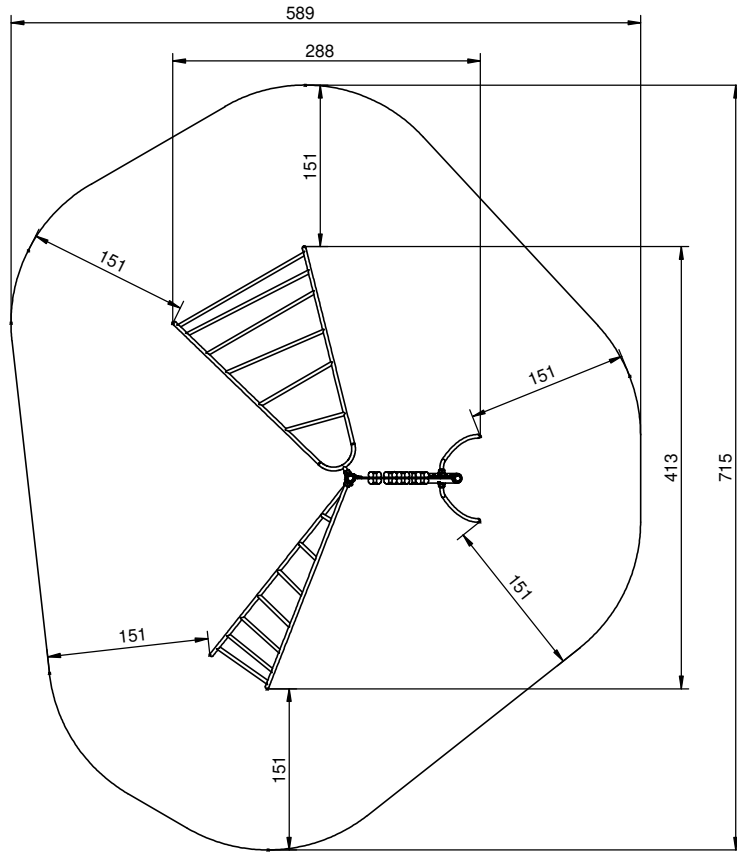

1114N

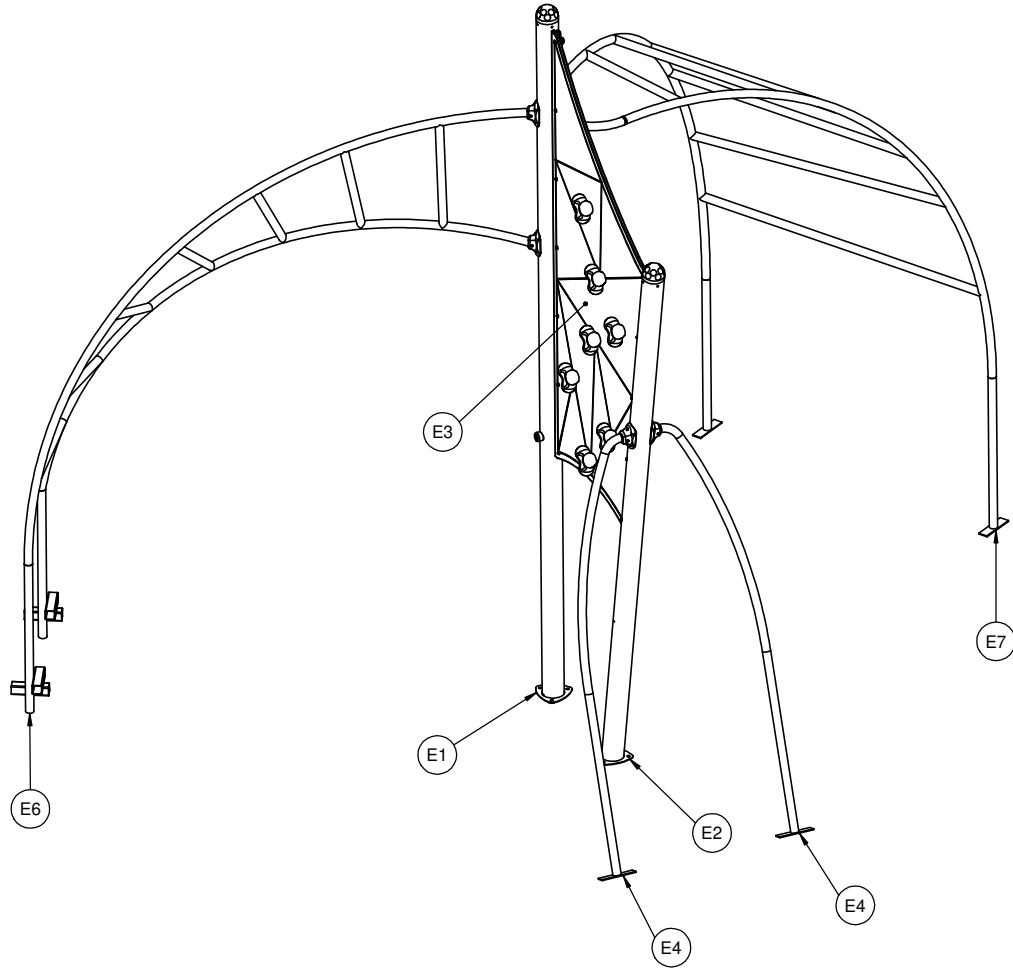

1114F

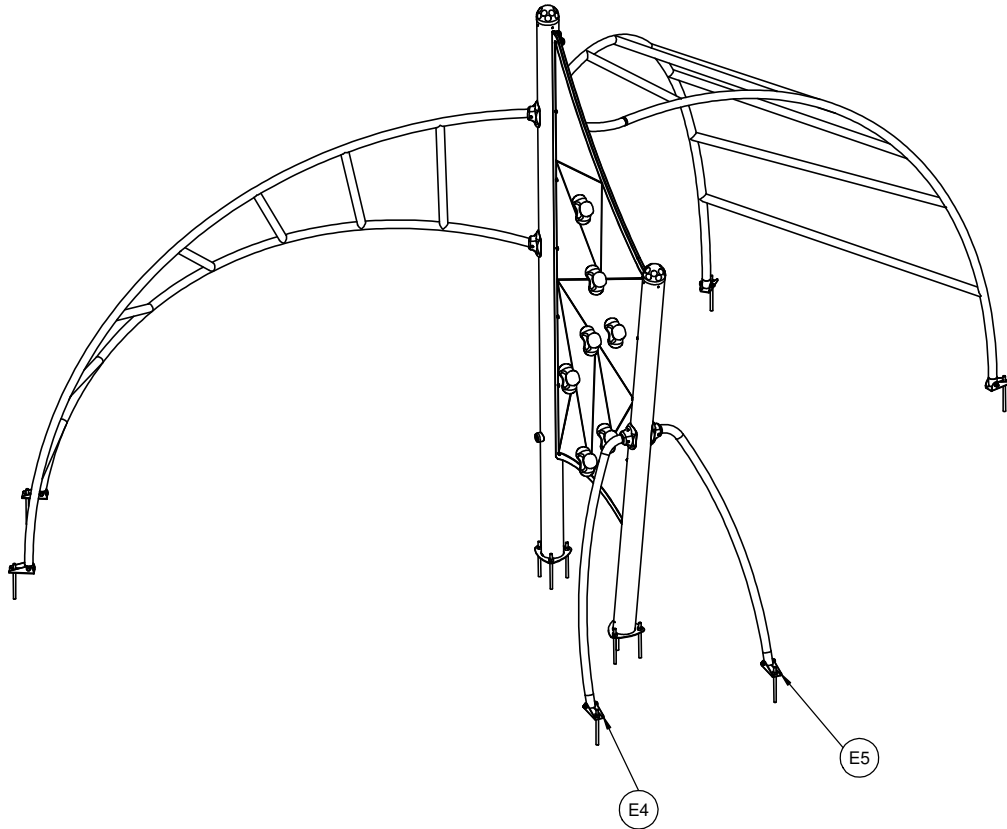

1

1114N



INST_11_24

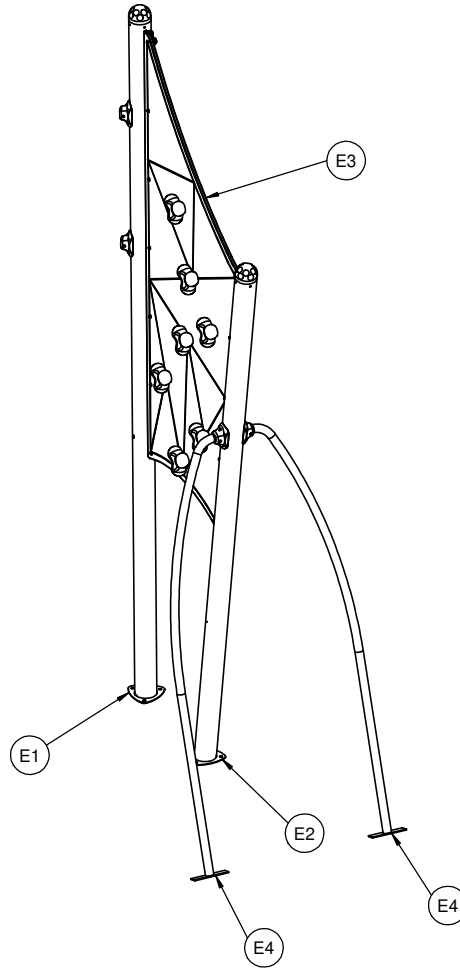

1

1114F



INST_11_24

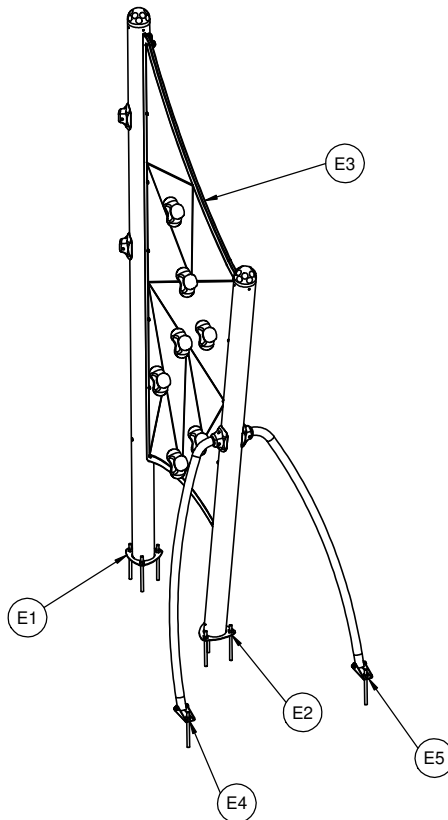

2

1114N
1114F



INST_11_08

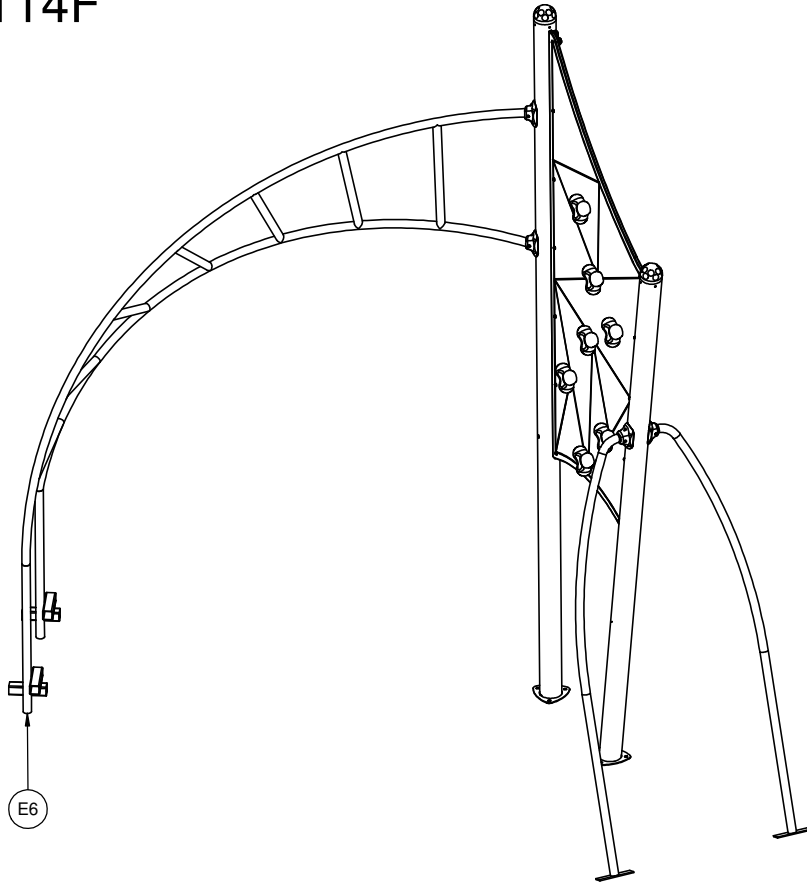

3

1114N
1114F



INST_11_09

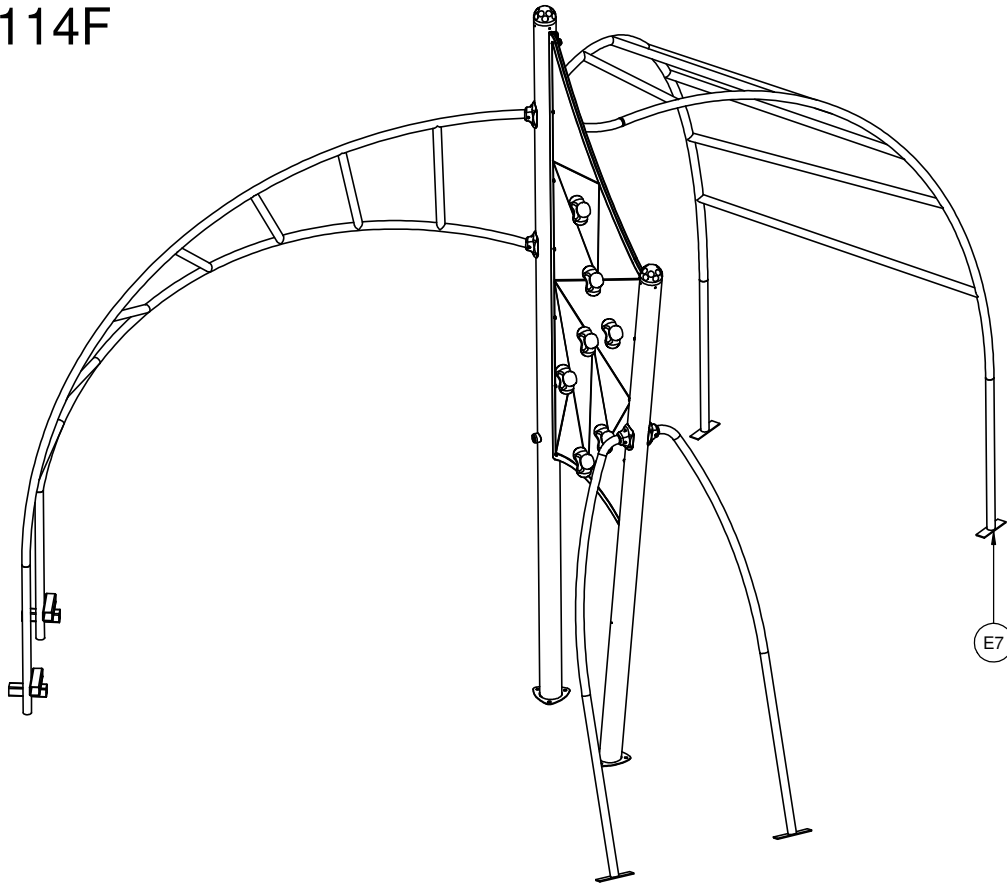

4

1114N
1114F



INST_Z_1

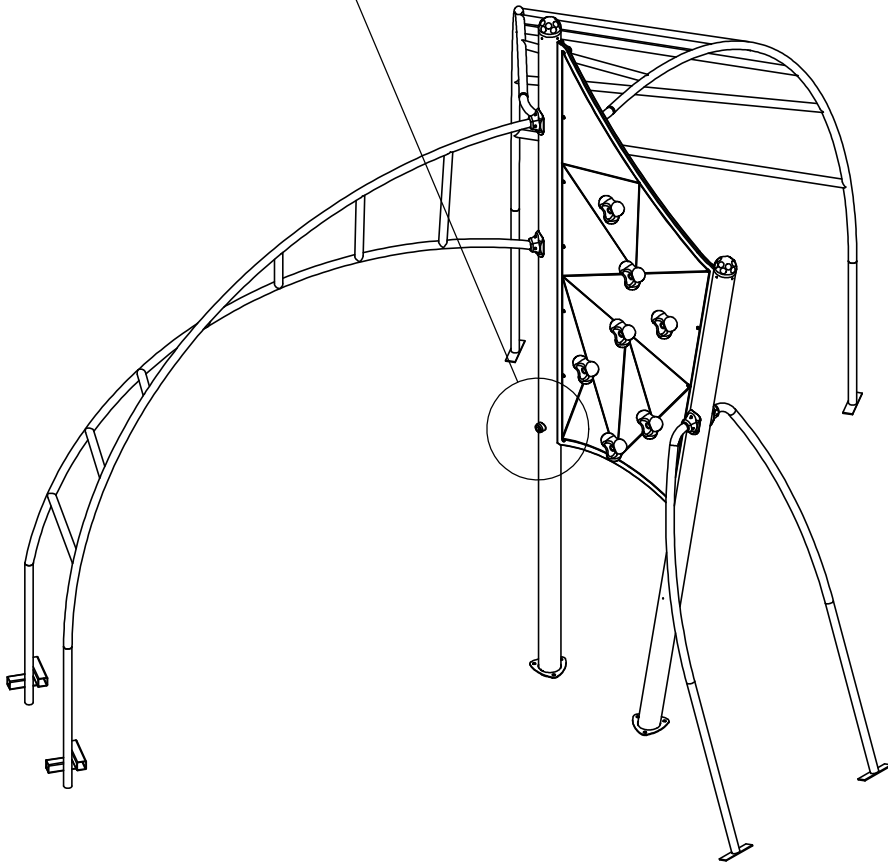
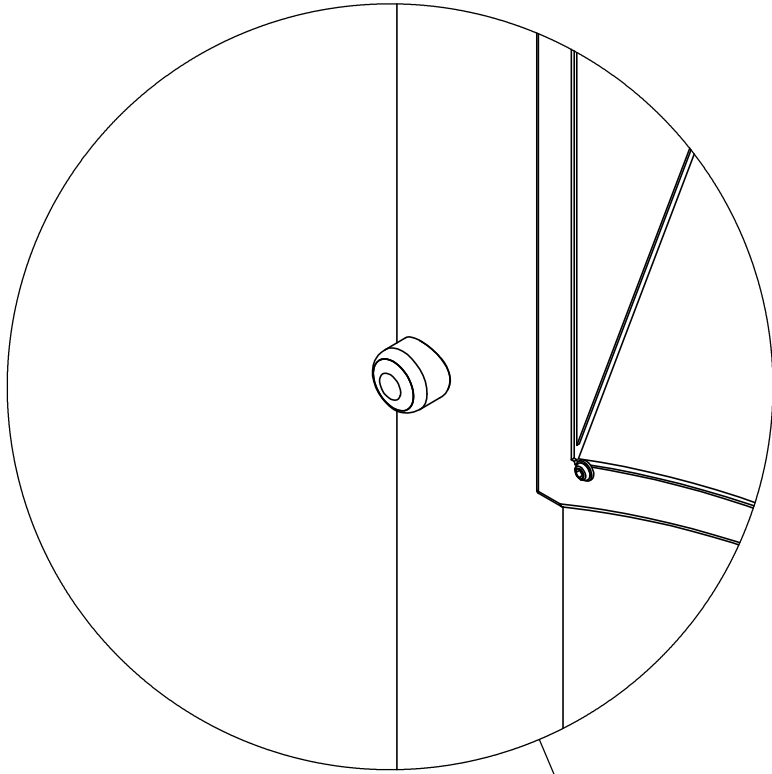

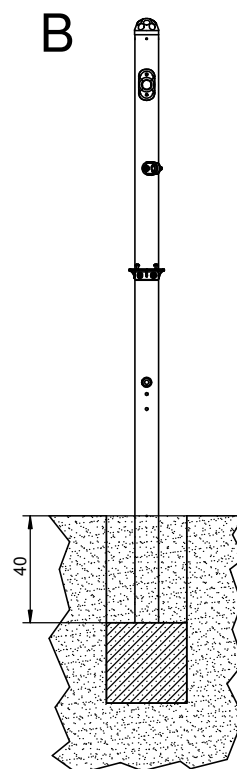
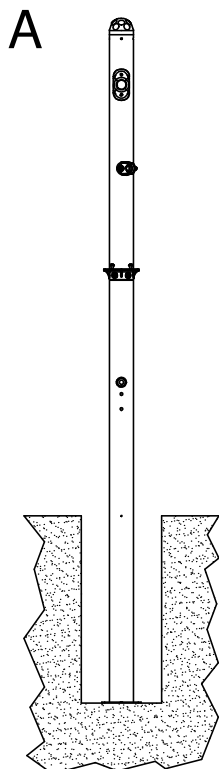
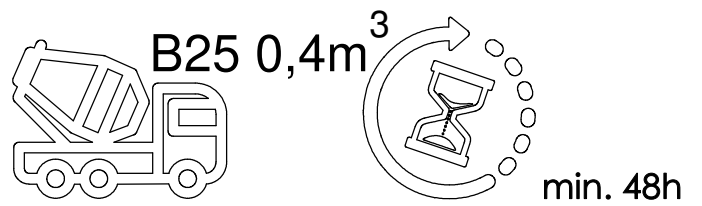
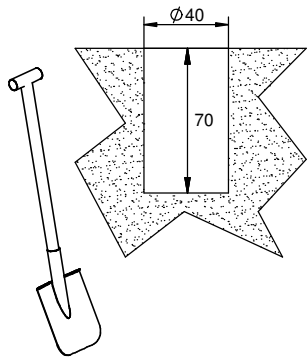
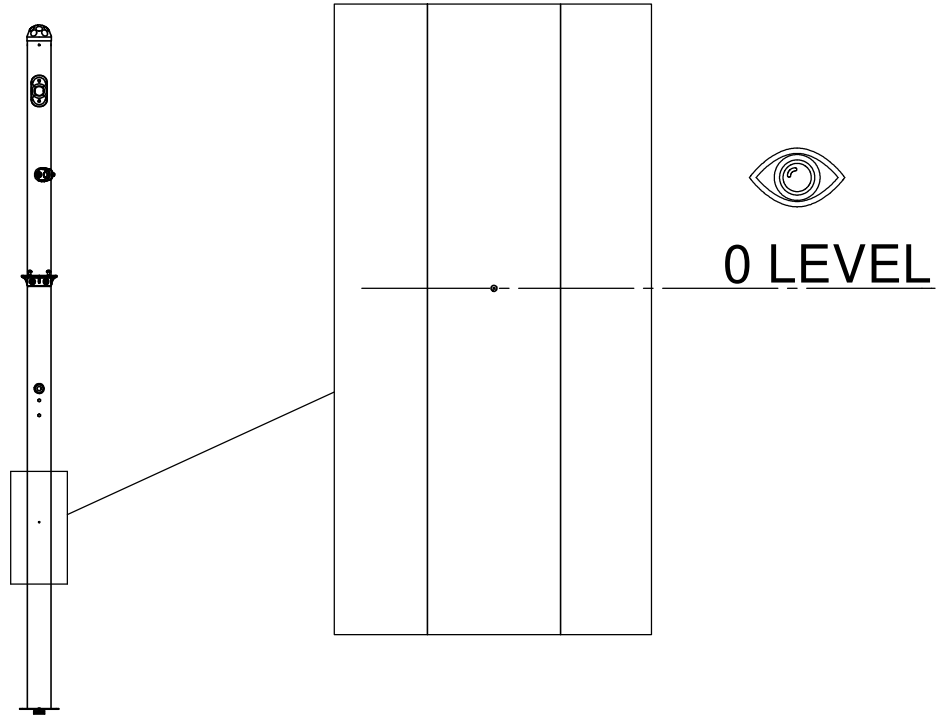

1114N

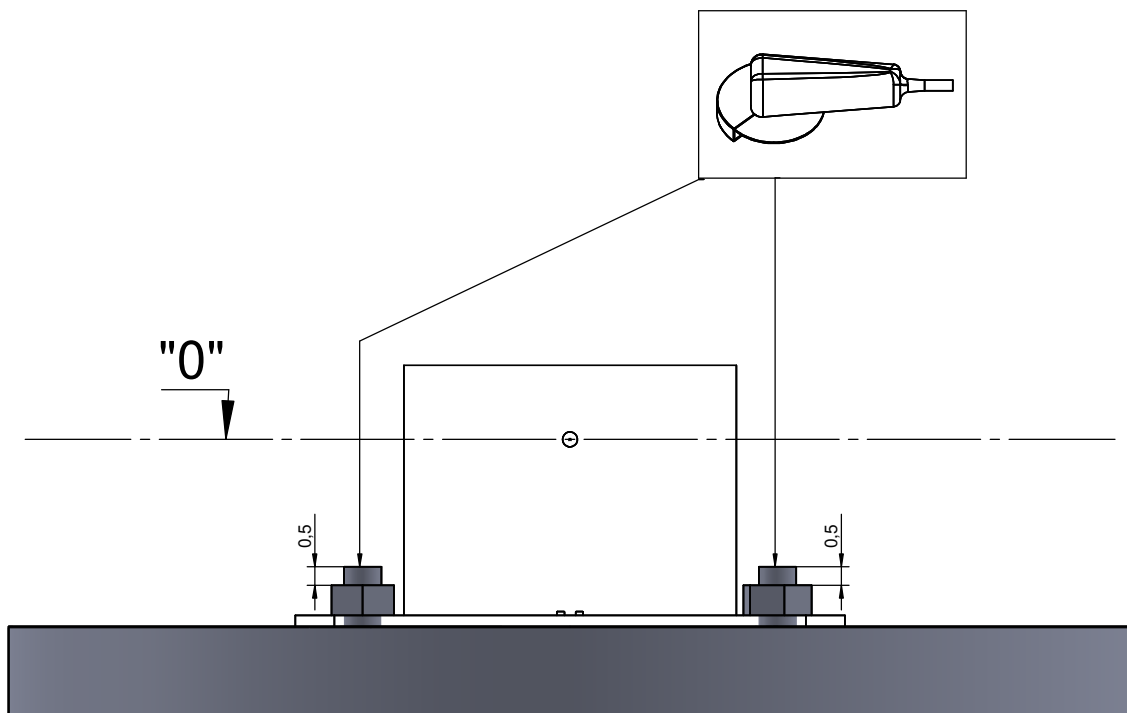
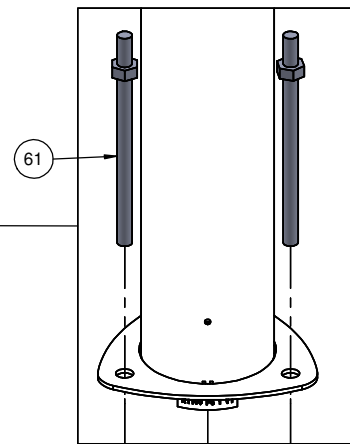
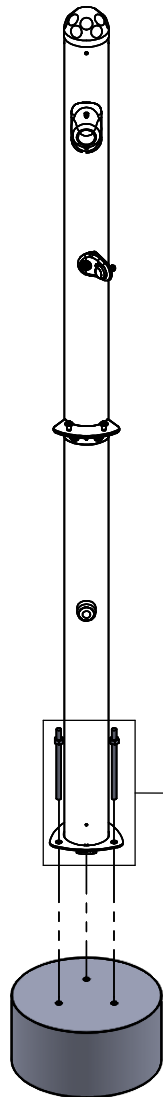
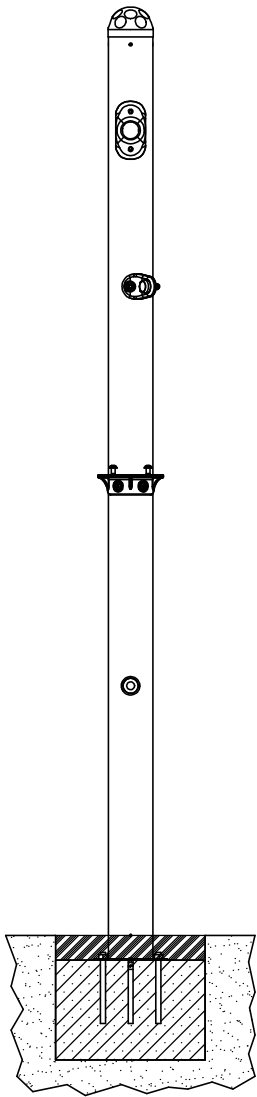

1114F

Nr	Σ	Element	DIN	ELEMENT
61	3		-	KL105



Nr	Σ	Element		
58	-		-	LIIMA

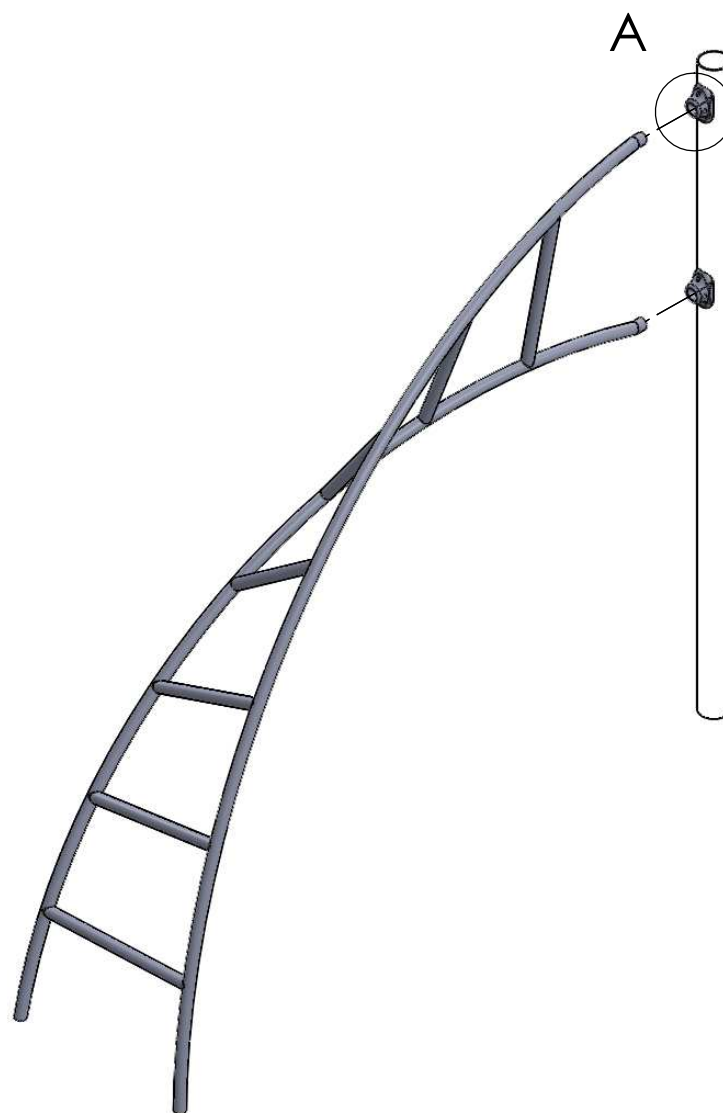

A (1 : 2)

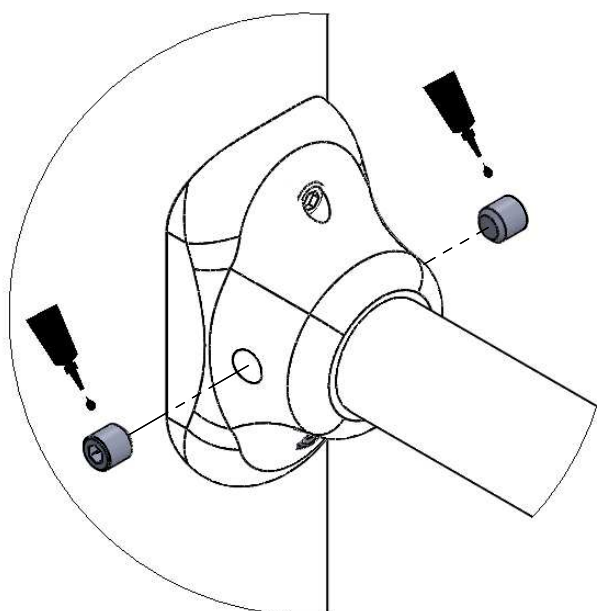

Nr. 5

F

Nr	Σ	Element	DIN	ELEMENT
61	2		-	KL105

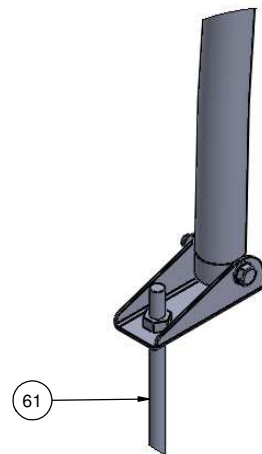
**B (1 : 5)**

Nr	Σ	Element		
58	-		-	LIIMA

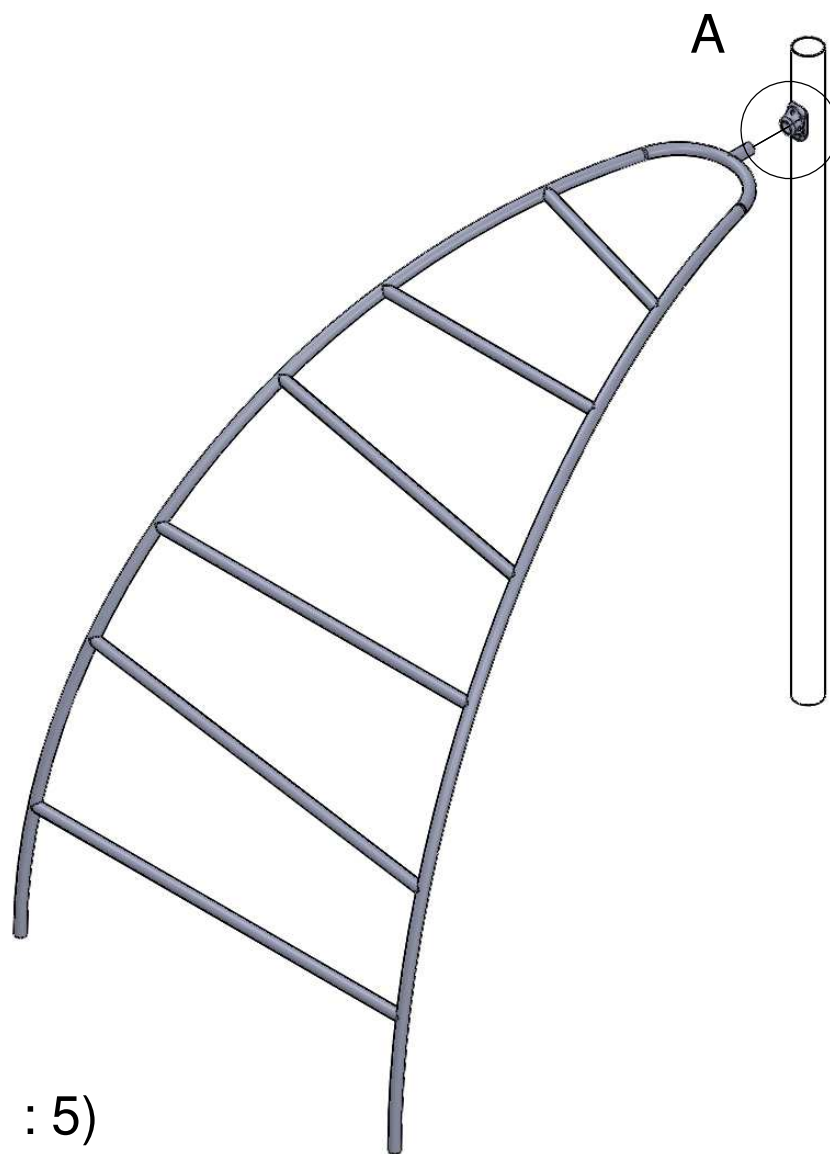

A (1 : 5)

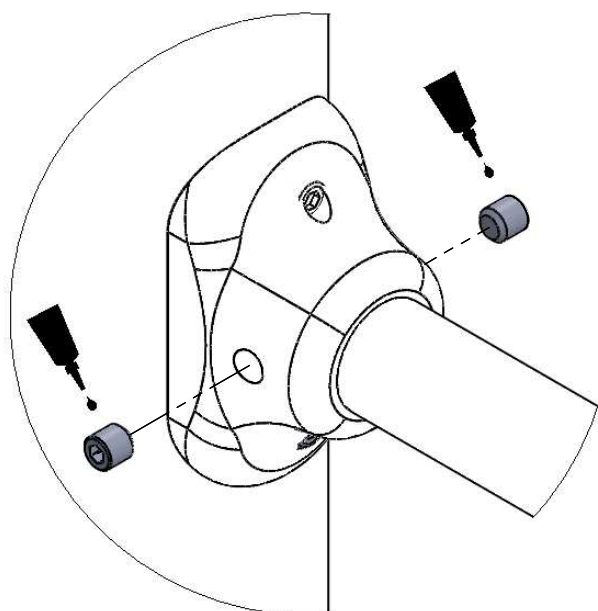





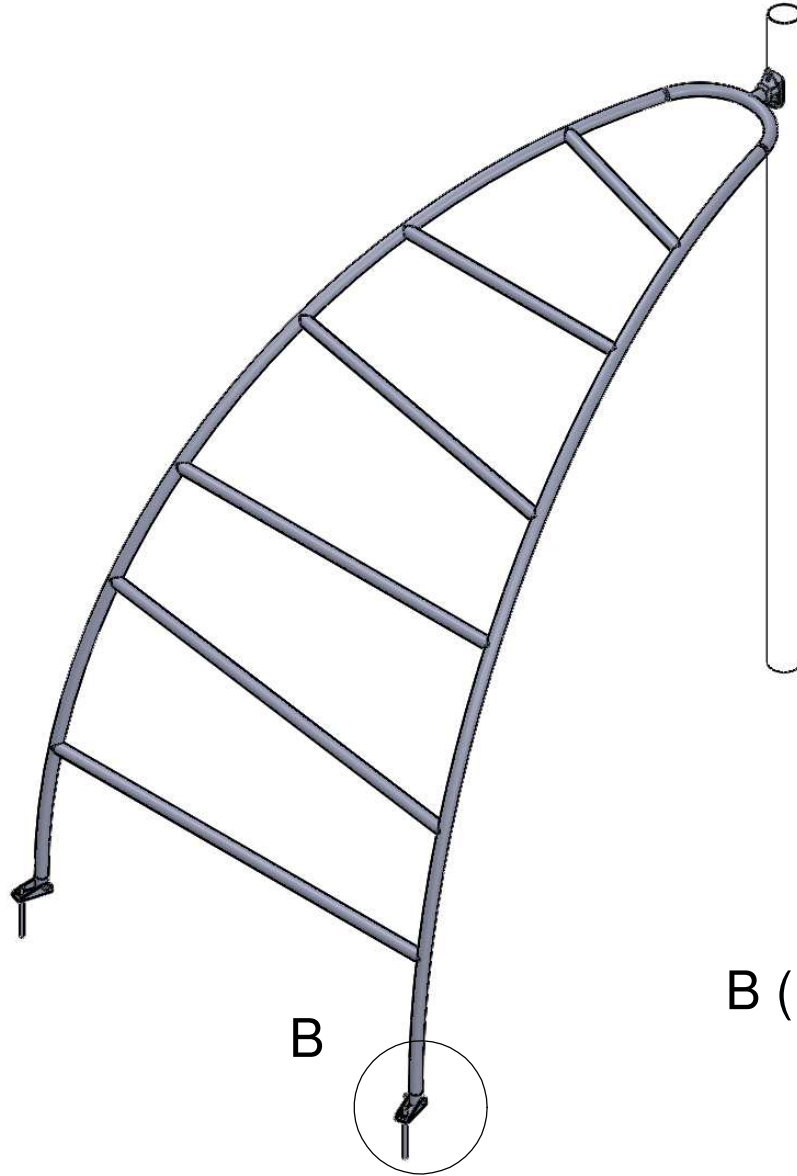
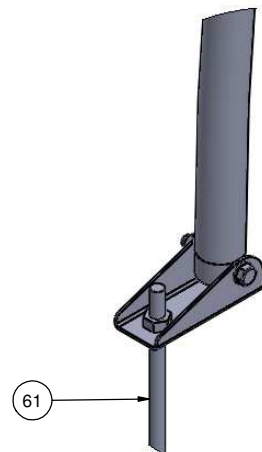

Nr. 5

F

Nr	Σ	Element	DIN	ELEMENT
61	2		-	KL105

**B (1 : 5)**

Nr	Σ	Element	DIN	ELEMENT
10	12		DIN 9021	6x18
15	12		ISO 7380	M6x30
16	12		-	K1_d21_B
17	12		-	Z1_d21_B
18	12		DIN 985	M6
22	12		DIN 125	6x12
58	1		-	LIIMA

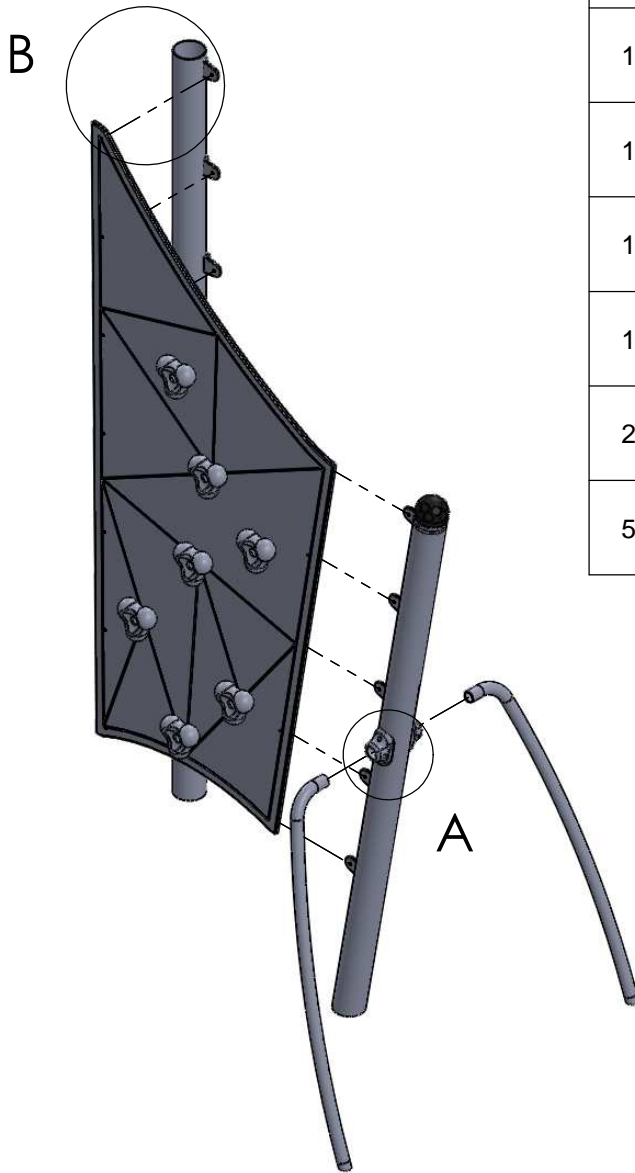

B (1 : 5)

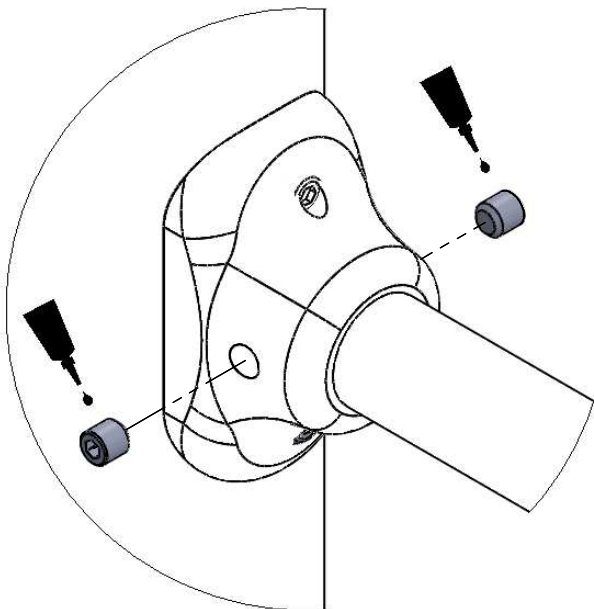
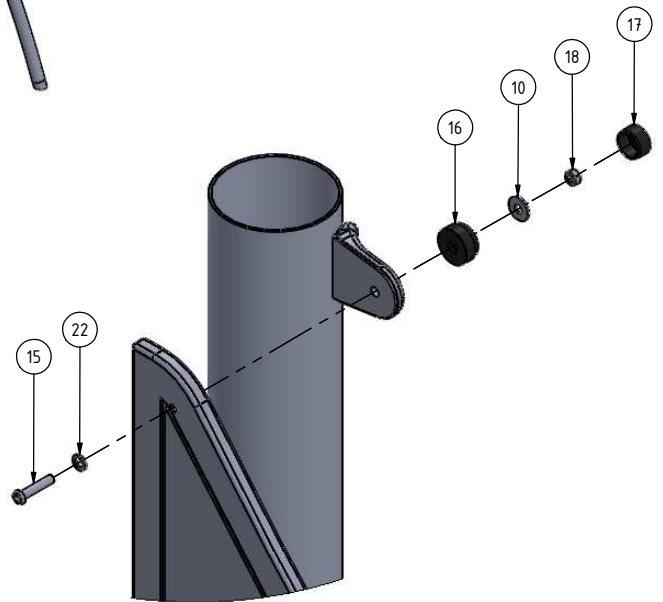

Nr. 5

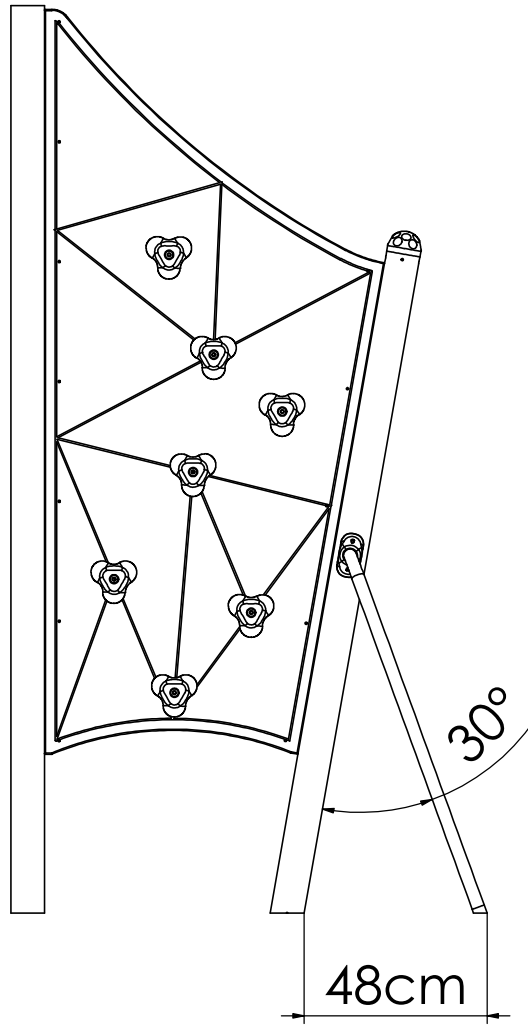

F

Nr	Σ	Element	DIN	ELEMENT
61	5		-	KL105

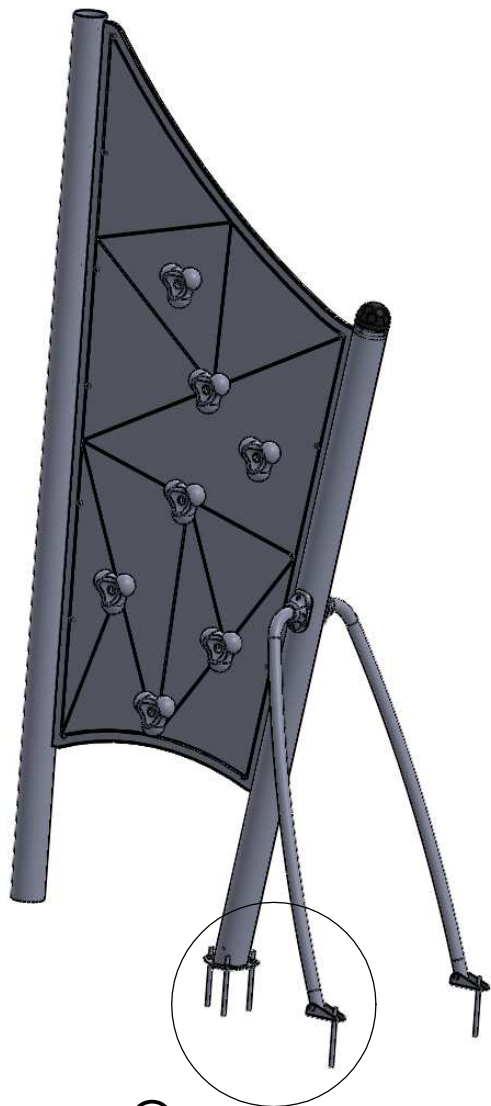



C

C (1 : 5)



INST_Z_1

Nr	Σ	Element		
213	1		-	Z_NA_1
214	1		-	Z_NA_2

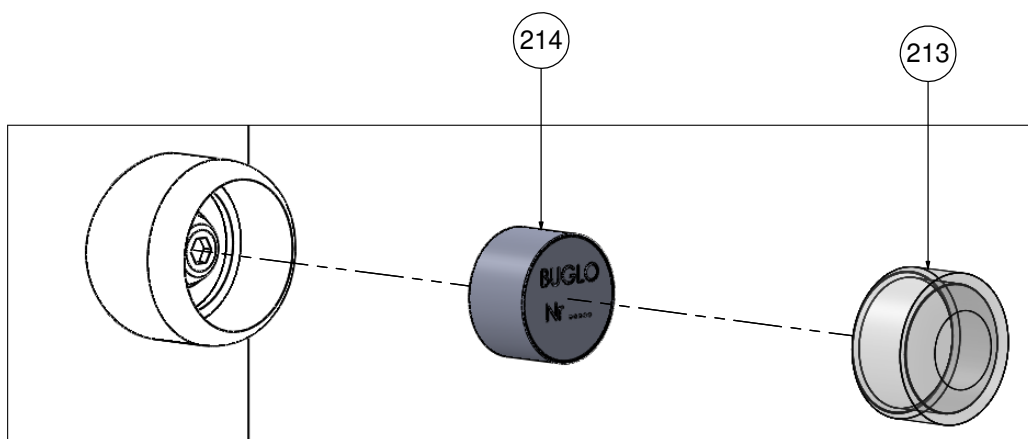
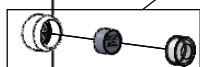

Tuotteen huolto-ohje

Leikkikenttävälineemme täyttävät EN-1176-1 : 2017- 12 -standardin turvallisuusvaatimukset.

On suotavaa ottaa yhteyttä tuotteen valmistajaan liittyen takuun alla olevien osien huoltotöihin. Vahingoittuneet maalipinnat tulee puhdistaa pölystä, rasvasta ja ruosteesta. Tämän jälkeen puhdistettu pinta tulee peittää ruostumattomalla pohjamaalilla ja sitten maalata kahdesti teräspinoille tarkoitetulla maalilla.

LeikkiSet Oy:n käyttämät väriyhdistelmät:

- 1) Harmaa - RAL 7035
- 2) Keltainen - RAL 1003
- 3) Sininen - RAL 5015
- 4) Punainen - RAL 3000
- 5) Vihreä - RAL 6018
- 6) Musta - RAL 9005
- 7) Violetti - RAL 4008
- 8) Antrasiitti - RAL 7016
- 9) Hopea - RAL 9006
- 10) Beige - RAL 1019
- 11) Oranssi - RAL 2009

Puu vaatii säännöllistä huolenpitoa. Ilmasto-olosuhteista, käyttöasteesta ja mekaanisista vaurioista riippuen on suositeltavaa uudistaa kyllästyskerros 2 - 5 vuoden kuluttua.

Suosittellemme käyttämään tuotteita: GORI 356 puunsuoja-ainetta ja NORDICA EKO 3330-12-BASE T pintamaalia (väri 1806), nämä löydät sivustolta www.teknos.com.

Suosittelavaa on, että osat jotka ovat ruostumatonta terästä puhdistetaan kerran vuodessa, jotta epäpuhtaudet eivät aiheuta värimuutoksia teräkseen. Pese puuvillaliinoilla ja veteen liuotetulla miedolla pesuaineella, esim. astianpesuaine. Puhdistuksen jälkeen huuhtelee vedellä ja pyyhi kuivaksi.

HUOMIO! Ruostumattoman teräksen puhdistukseen käytettävät puhdistusaineet eivät saa sisältää: klooria, suolaa, happoja tai valkaisuaineita. Jo pieni määrä näitä aineita voi aiheuttaa kromioksidipinnan pysyviä vaurioita

- 1) Kausittainen tarkastus - kun väline on aktiivisessa käytössä, tulee sen kunto tarkastaa viikoittain tai useammin. Samalla tulee tarkistaa mahdolliset välineeseen kohdistuneet ilkeivät teot.

Kausittainen tarkastus pitää sisällään:

- Rakenteiden vakauden tarkistaminen
- Yleinen tarkastus osien puuttumisen varalta
- Tarkistaminen halkeamien, terävien reunojen ja muiden vaurioiden varalta
- Välineen ympäristön siisteys
- Mahdollisen turva-alustan kunnon tarkistaminen

- 2) Välineen sisäinen valvonta - tulee suorittaa kerran kolmessa kuukaudessa. Se pitää sisällään yleistarkastuksen, minkä lisäksi tulee tarkistaa myös välineen toiminnot.

Sisäinen valvonta pitää sisällään:

- Mahdollisen turva-alueen pinnan tarkistaminen ja mittaaminen (jos pinta on yli 10cm alle oikean tason, pitää sitä täydentää)
- Kaikki ruuvit ja mahdolliset kaapelit sekä verkot tulee kiristää

3) Vuositarkastus (pakollinen)

- Rakenteiden vakauden tarkistaminen
- Mahdollisten ruostevaurioiden tarkastaminen ja korjaaminen
- Perustusten tarkistaminen
- Mahdollisen turva-alueen pinnan tarkistaminen ja mittaaminen (Jos pinta on yli 10cm alle oikean tason, pitää sitä täydentää)

Kaikilla laitteilla on oltava säännöllinen tarkastusvalvonta. Tarkastuksen tekijän tulee kirjata tiedot tarkastuksesta ylös.