

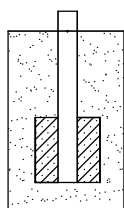

Leikin ja liikunnan edelläkävijä.

1109 Torniliuku asennusohje

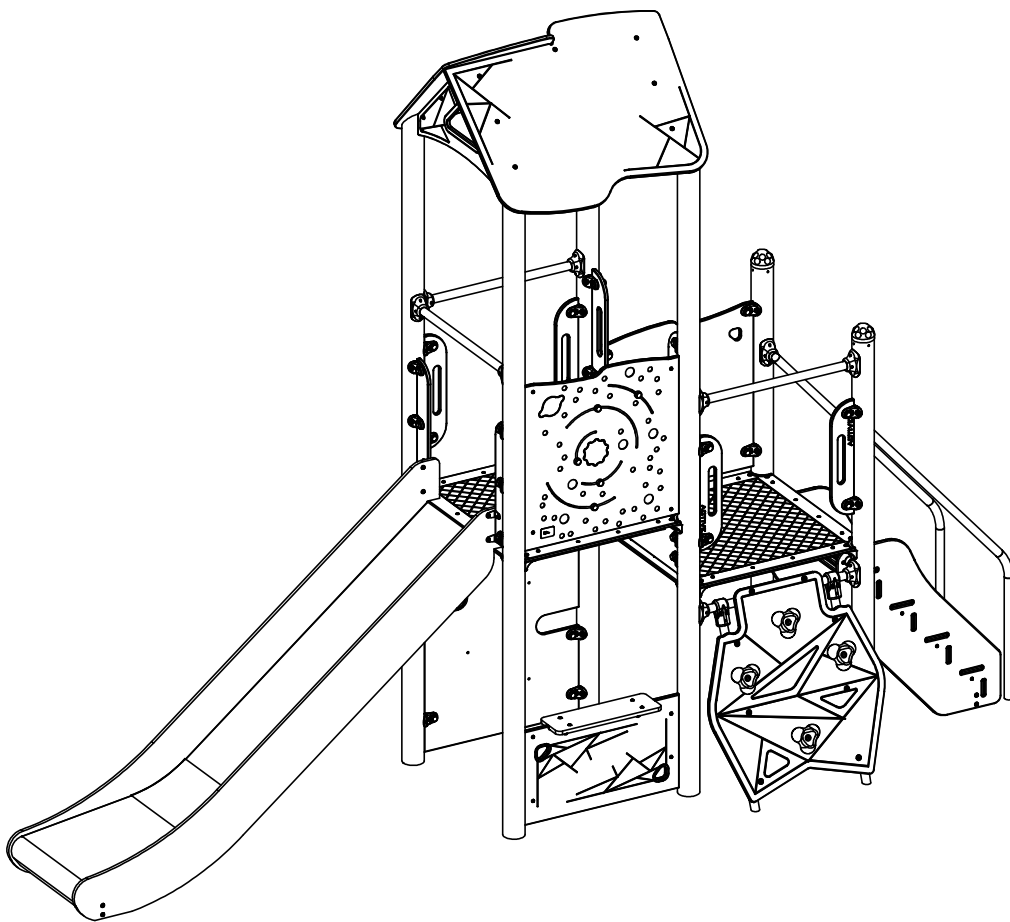

1109N

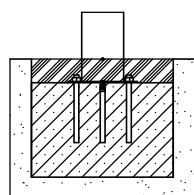

1109F

Pinta-asenteinen

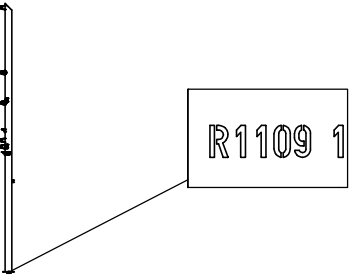
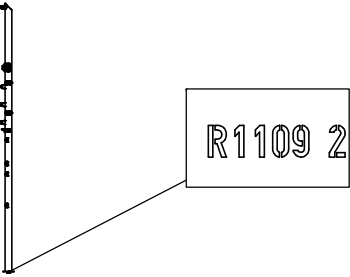
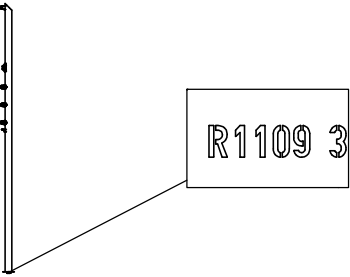
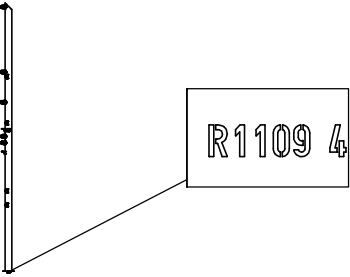
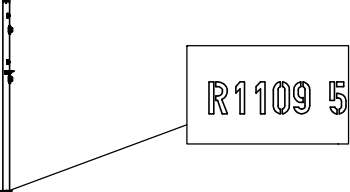
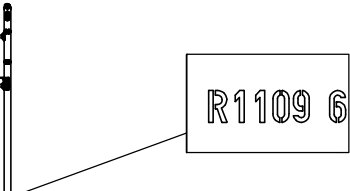
NR	ELEMENT	1109N	1109F
E1		1	1
E2		1	1
E3		1	1
E4		1	1
E5		1	1
E6		1	1

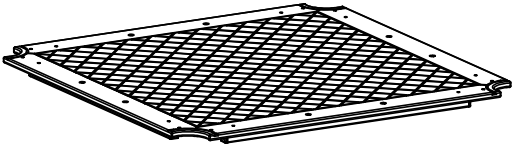
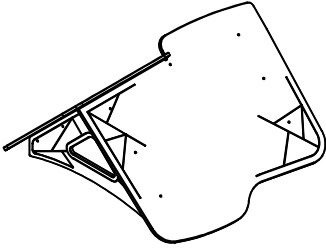
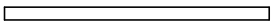
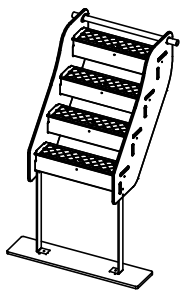
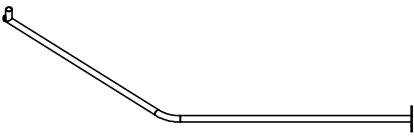
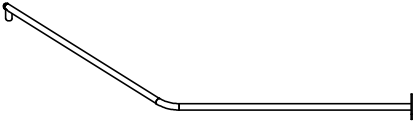
NR	ELEMENT	1109N	1109F
E7	 <p>F11P_1_HP_g13_v2 83cm x 83cm</p>	2	2
E8		1	1
E9	 <p>R1100_3_Y_v1 L= 70cm</p>	3	3
E10	 <p>H=90cm</p>	1	1
E11	 <p>H=90cm R</p>	1	1
E12	 <p>H=90cm L</p>	1	1

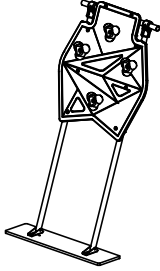
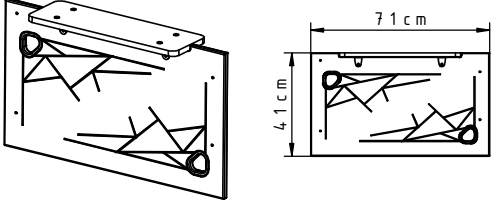
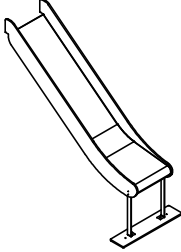
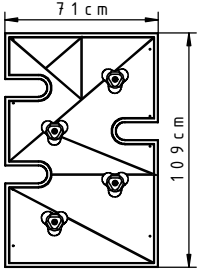
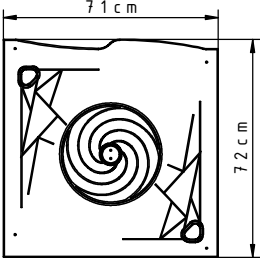
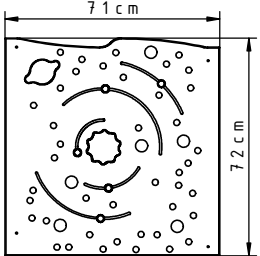

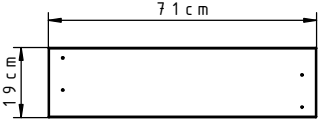
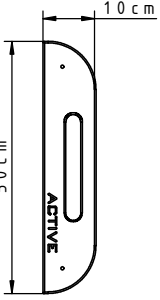
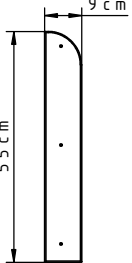
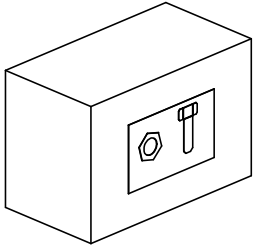
NR	ELEMENT	1109N	1109F
E13	 <p>H=90cm</p>	1	1
E14		1	1
E15	 <p>H=120cm</p>	1	1
E16	 <p>F11W_5_HP_g13_v1</p>	1	1
E17	 <p>F1100_0_PE_g15_v1 + M5</p>	1	1
E18	 <p>F1100_24_PE_g15_v1</p>	1	1

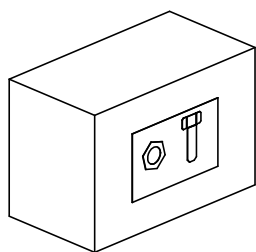
NR	ELEMENT	1109N	1109F
E19	 <p>F11X_12_PE_g15_v2</p>	1	1
E20	 <p>F11X_4_PE_g15_v2</p>	6	6
E21	 <p>F11X_11_PE_g15_v1</p>	2	2
E22		1	1



1109N

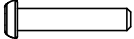

1109F

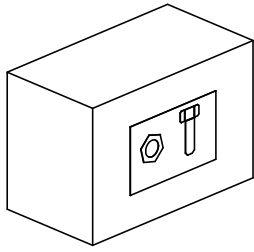
Nr	Element	DIN	ELEMENT	Σ	Σ
10		DIN 9021	6x18	58	58
15		ISO 7380	M6x30	8	8
16		-	K1_d21_B	58	58
17		-	Z1_d21_B	58	58
18		DIN 985	M6	46	46
21		DIN 125	8x16	24	32
22		DIN 125	6x12	42	50
23		-	M6x12	24	32
24		ISO 7380	M6x16	8	16
25		ISO 7380	M6x35	26	26
29		-	K_5_A2_g2_G_v2	4	4
51		ISO 7380	M6x45	12	12
58		-	LOCTITE	1	1
61		-	KL105		26
109		DIN 913	10x10	2	2
121		-	7100_5_A2_g3_G_v1		4
139		DIN 7991	M6x16	16	16



1109N

1109F

Nr	Element	DIN	ELEMENT	Σ	Σ
213		-	Z_NA_1	1	1
214		-	Z_NA_2	1	1

1109N
1109F

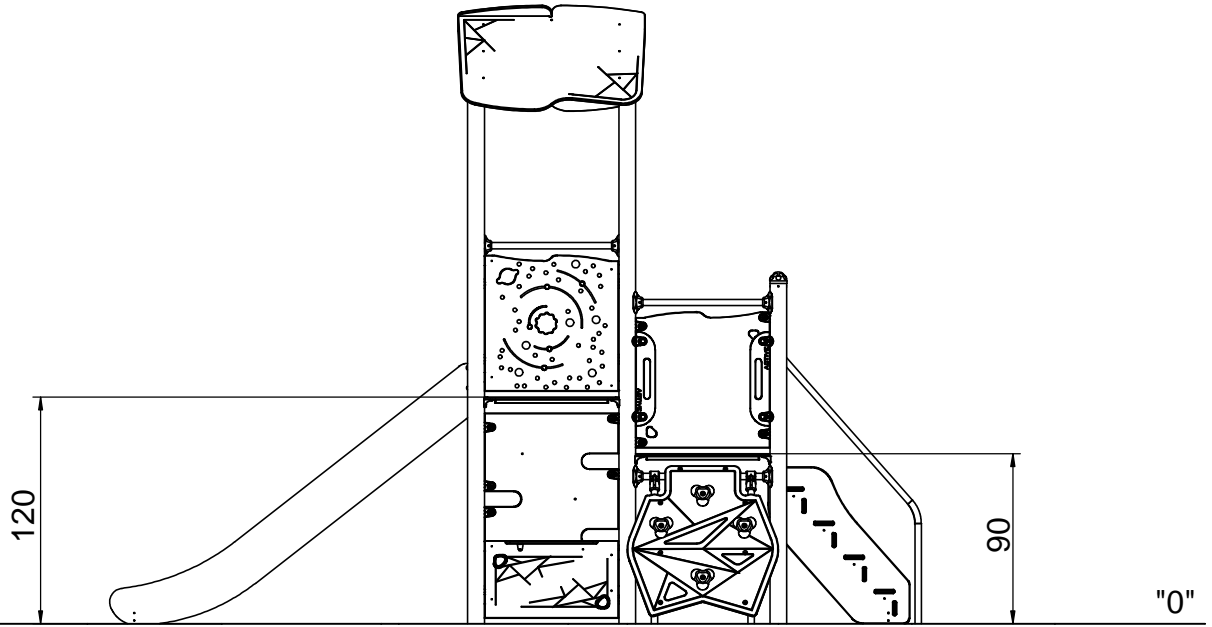

1109N
1109F

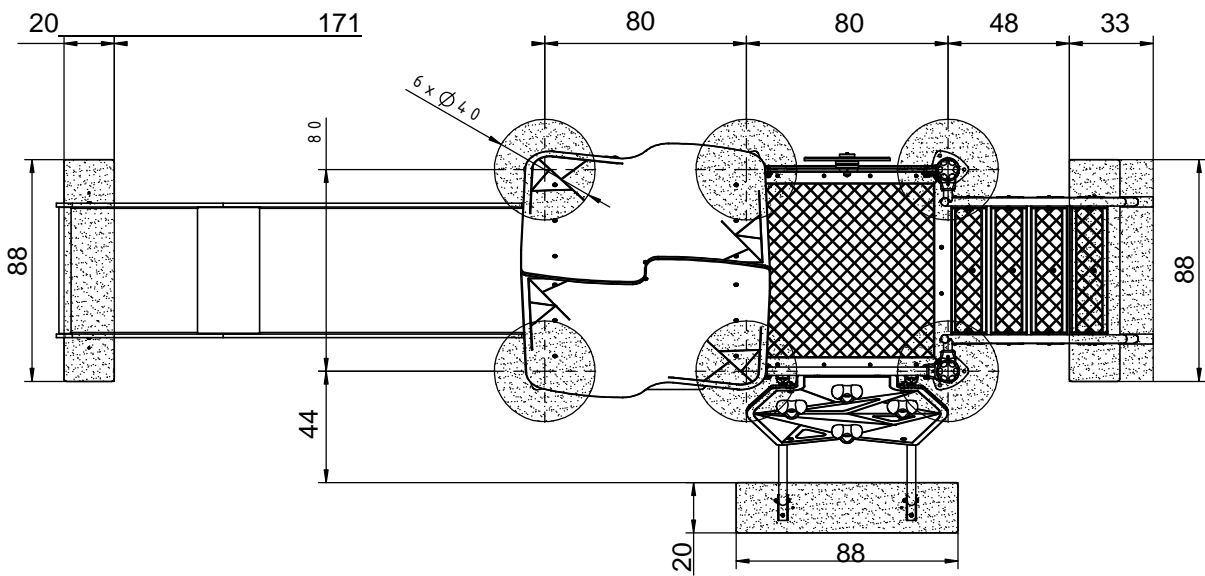
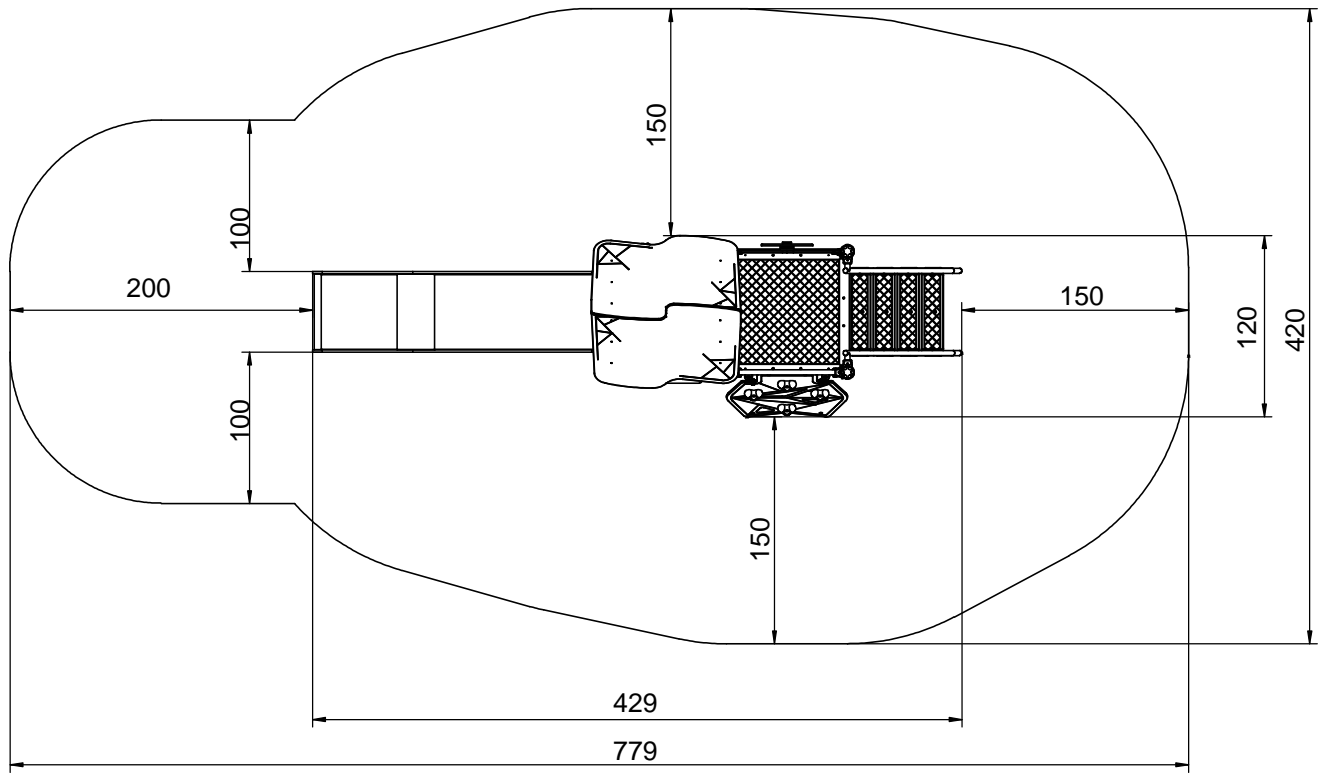

1109N
1109F

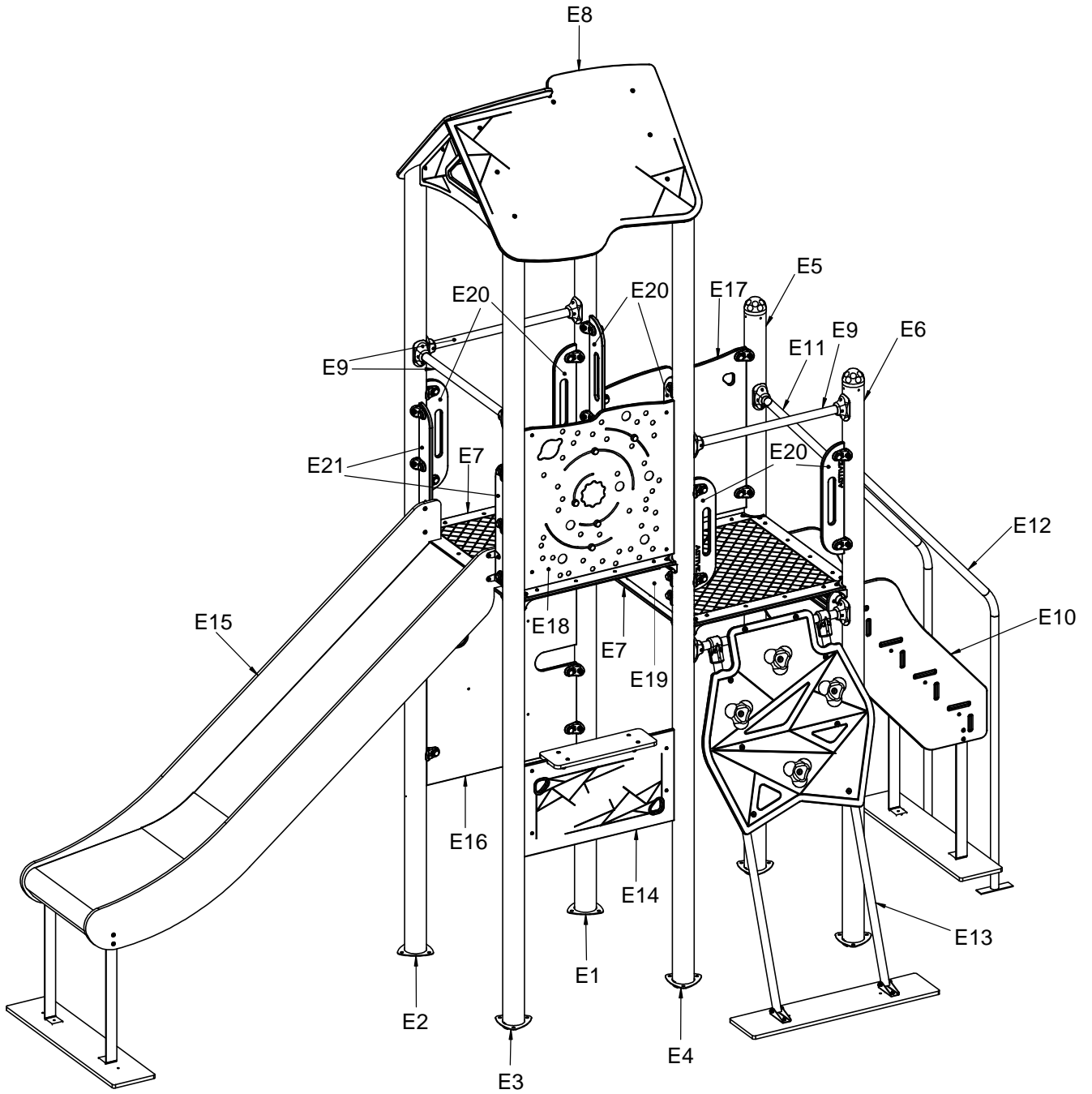

1

1109N
1109F



INST_11_18
INST_11_65

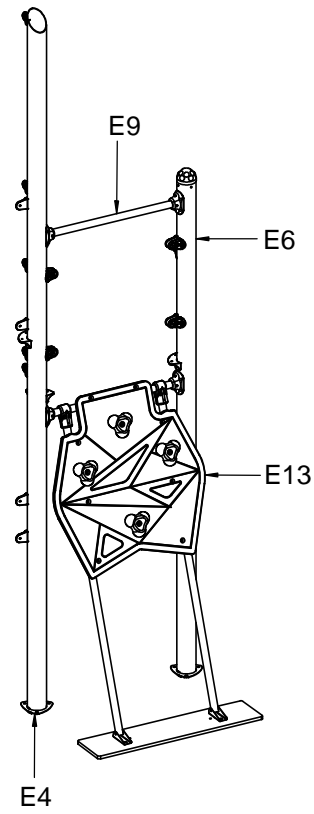



2

1109N
1109F

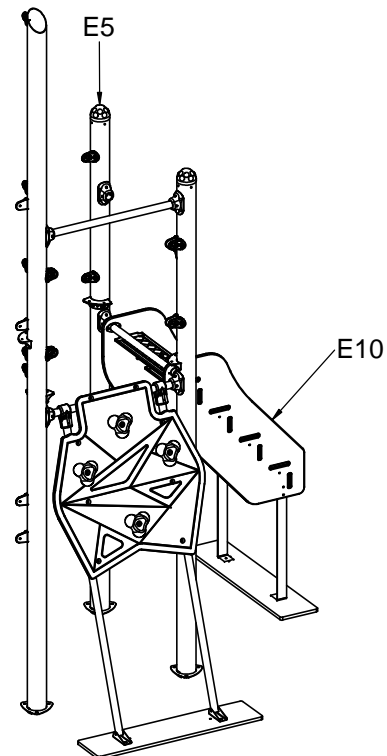

INST_11_62



Nr	Σ	Element		
58	1		-	LOCTITE

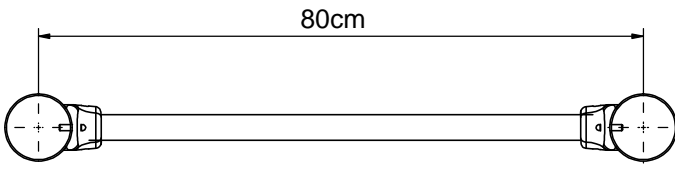
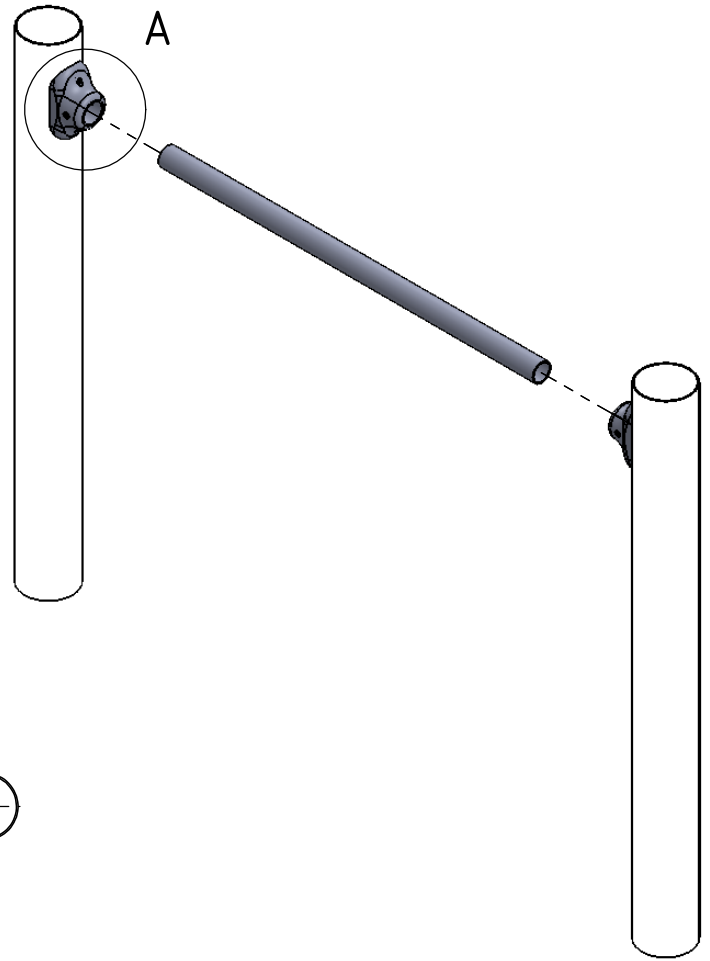

A (1 : 2)

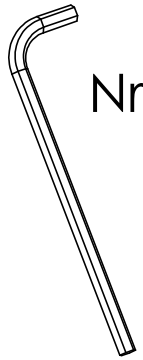
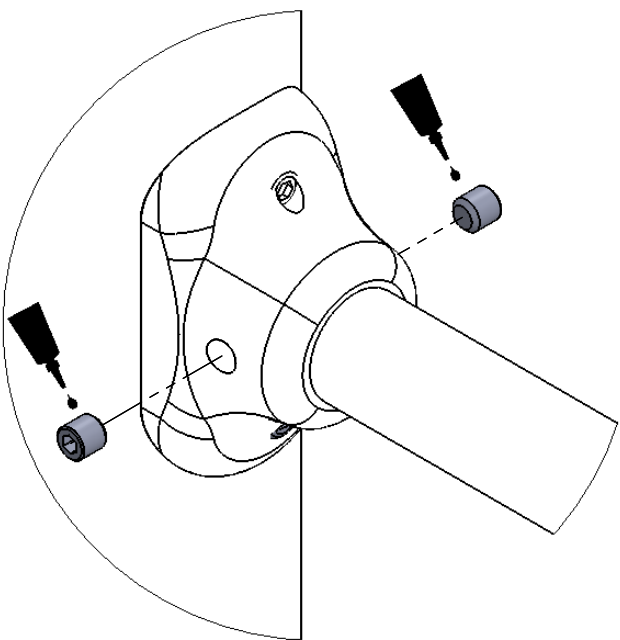

Nr	Σ	Element		
58	1		-	LOCTITE

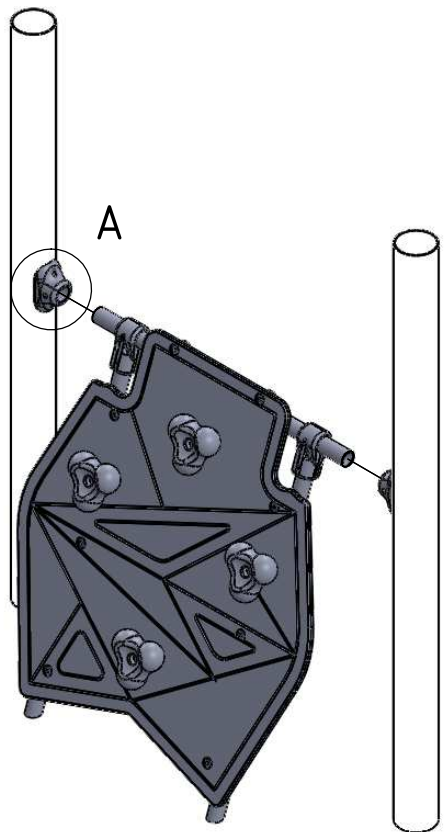
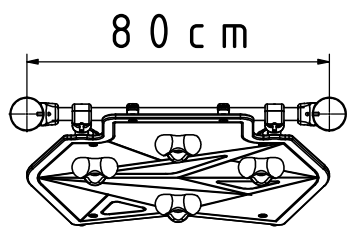
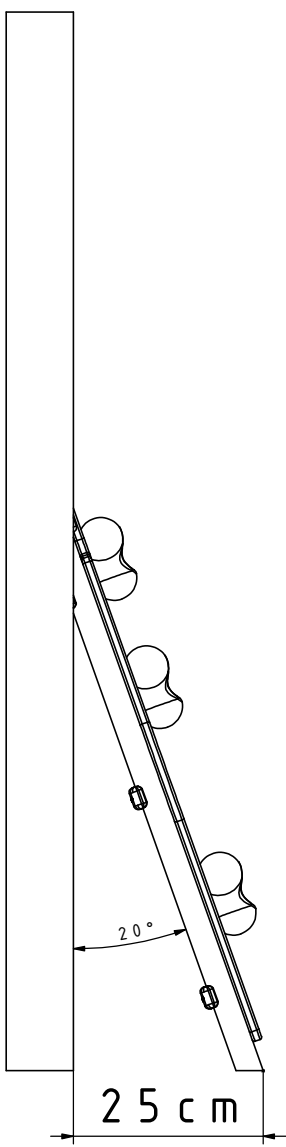

A (1 : 2)

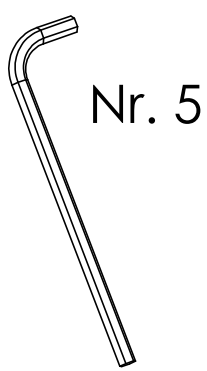
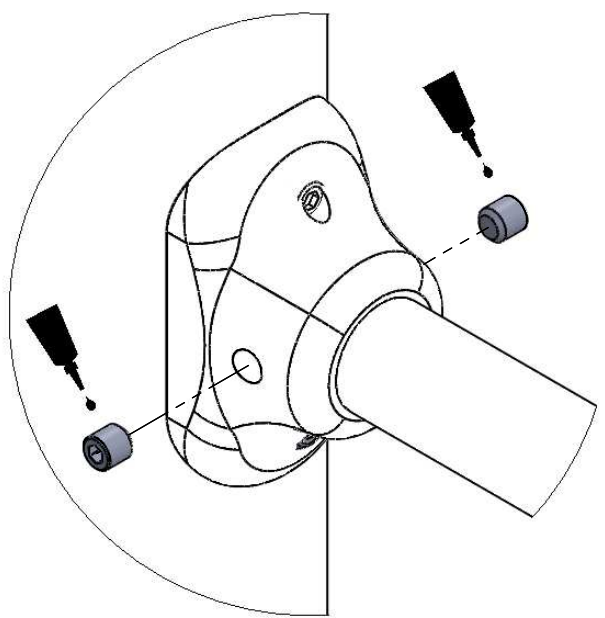

F

Nr	Σ	Element	DIN	ELEMENT
61	2		-	KL105

B (1 : 5)

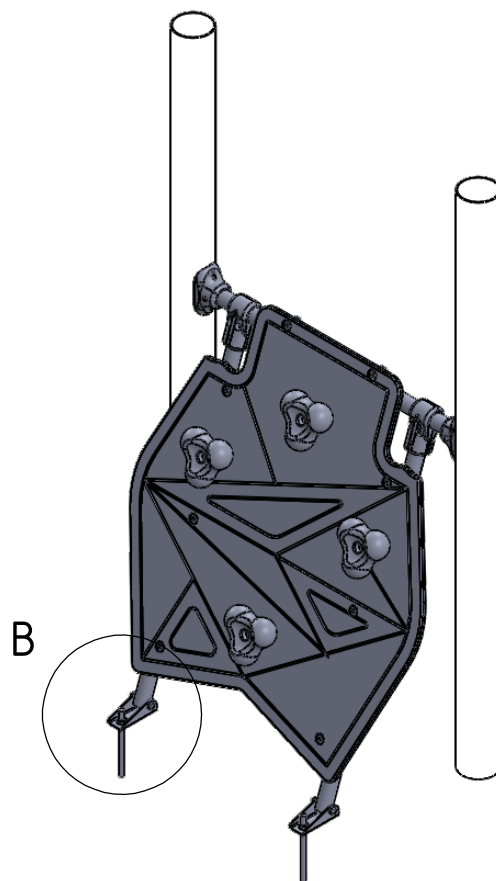
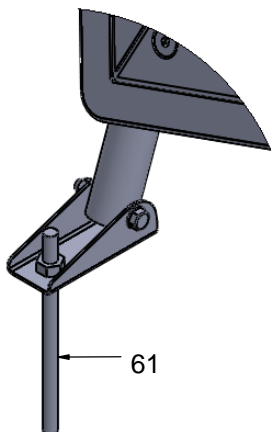



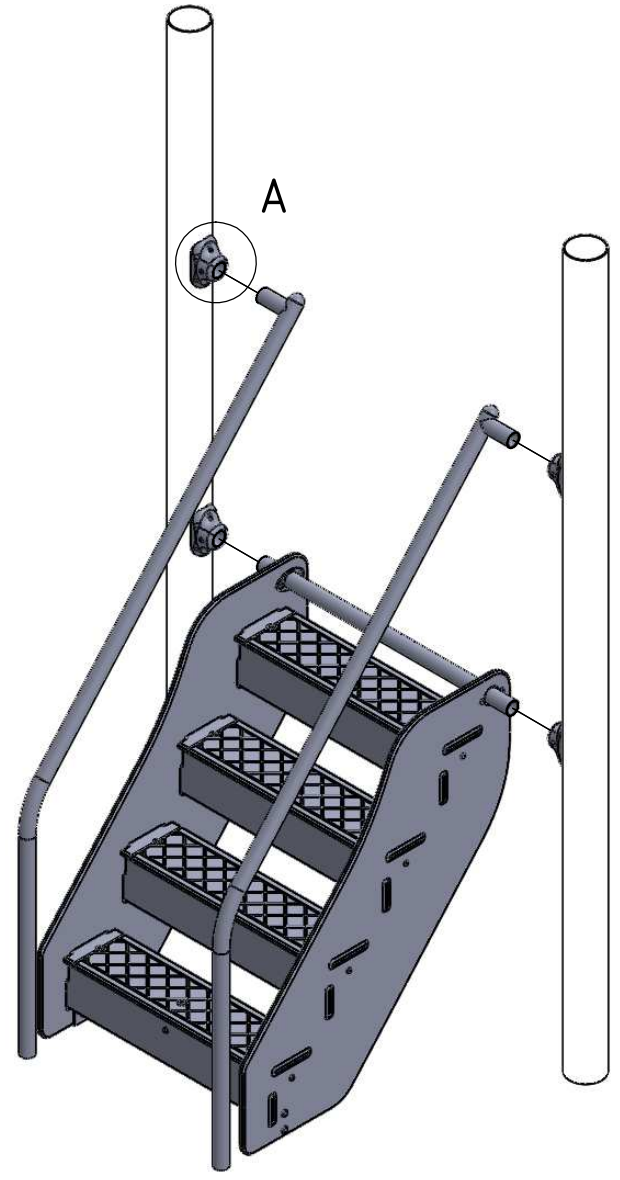
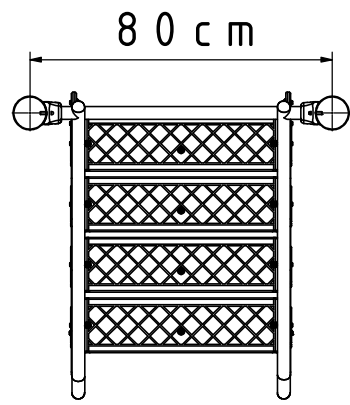
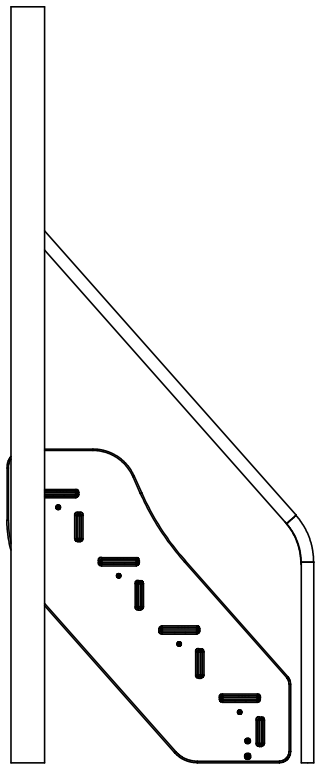

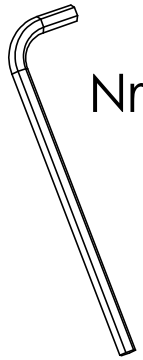
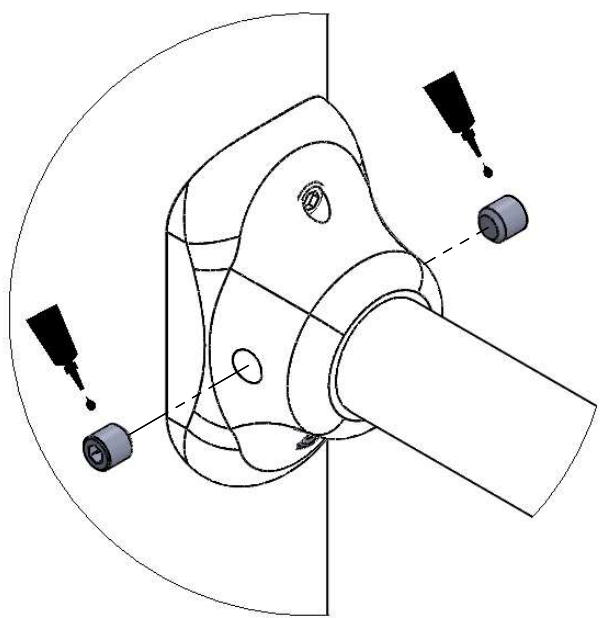

Nr	Σ	Element		
58	1		-	LOCTITE

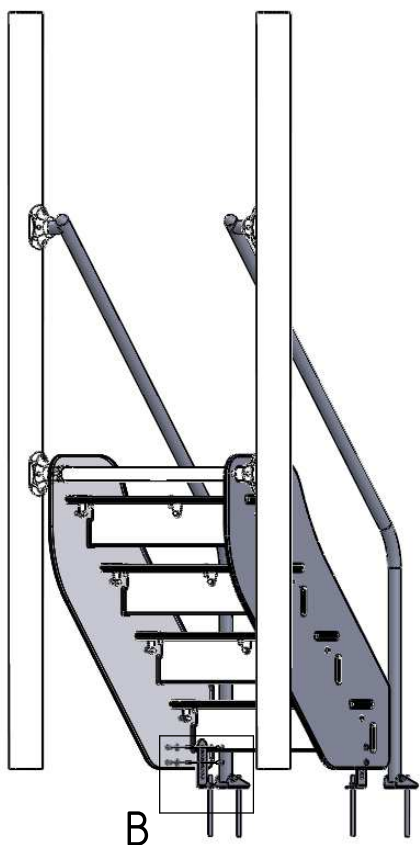

A (1 : 2)



F

Nr	Σ	Element	DIN	ELEMENT
21	4		DIN 125	8x16
22	4		DIN 125	6x12
23	4		-	M6x12
24	4		ISO 7380	M6x16
61	4		-	KL105
121	2		-	7100_5_A2_g3_G_v1

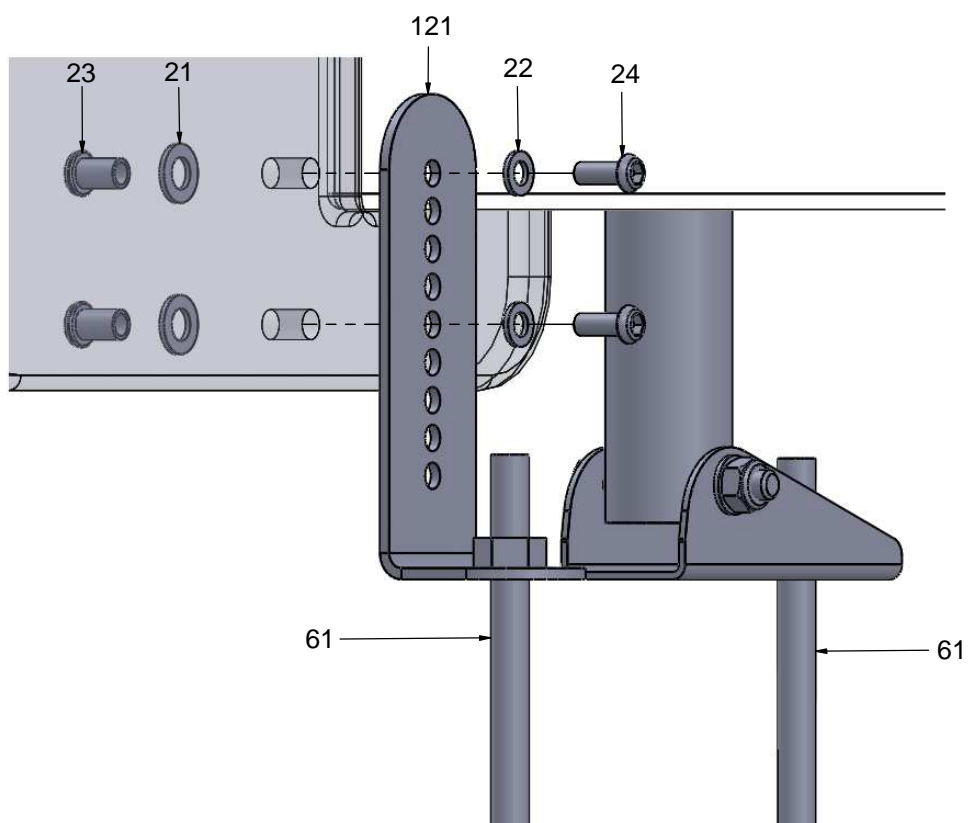
B (1 : 2)

3

1109N
1109F



INST_11_41
INST_11_68A

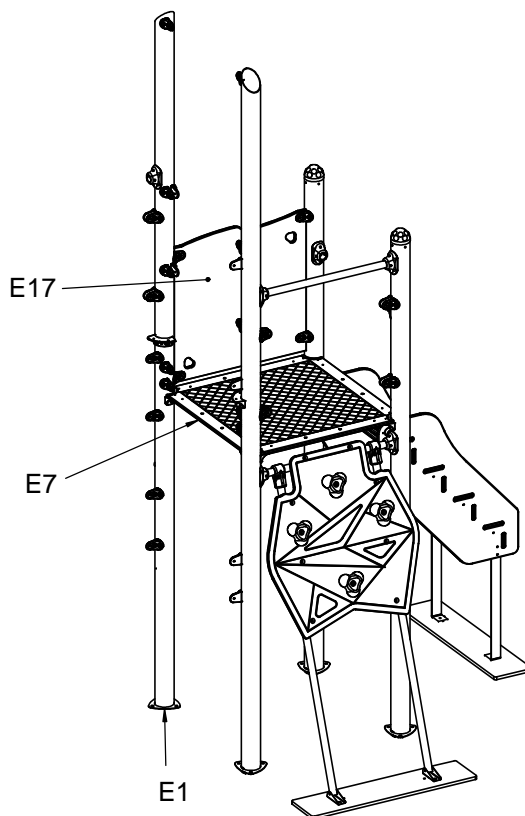





4

1109N
1109F

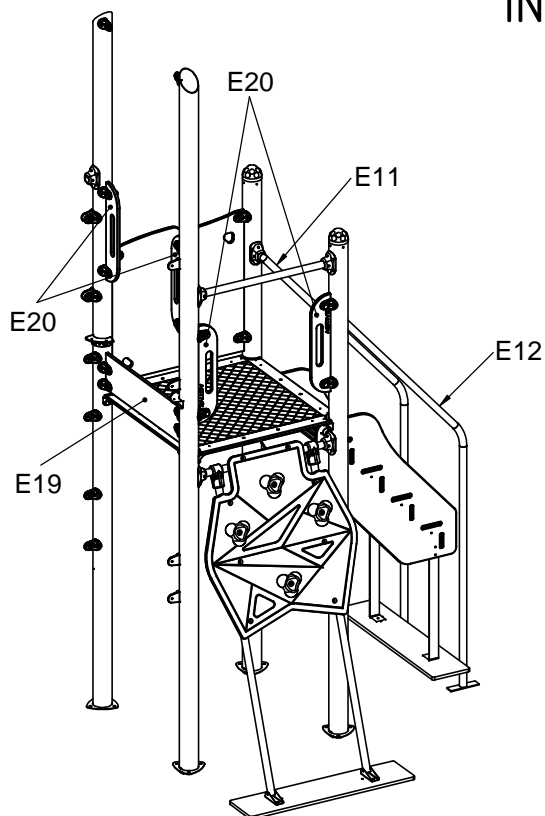

INST_11_62
INST_11_68A
INST_11_68B



Nr	Σ	Element	DIN	ELEMENT
21	8		DIN 125	8x16
139	8		DIN 7991	M6x16
23	8		-	M6x12

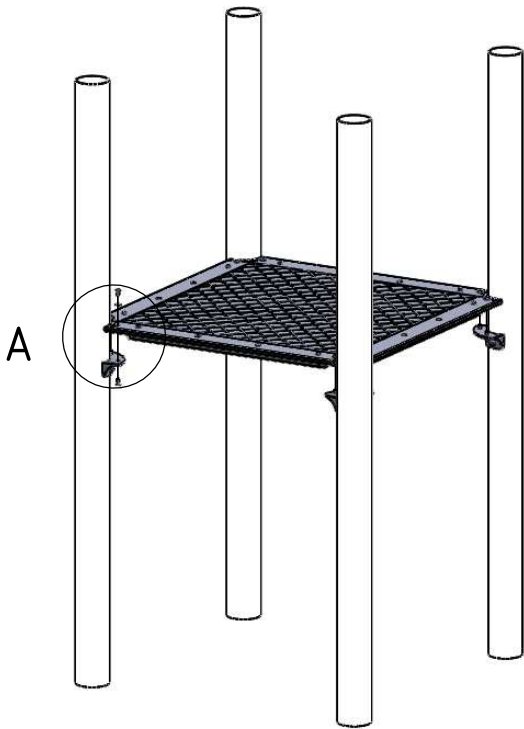



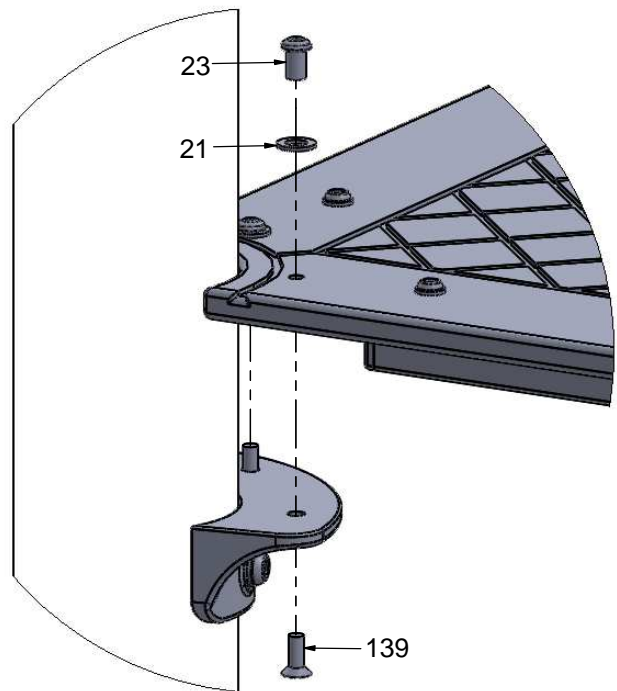

A (1 : 3)

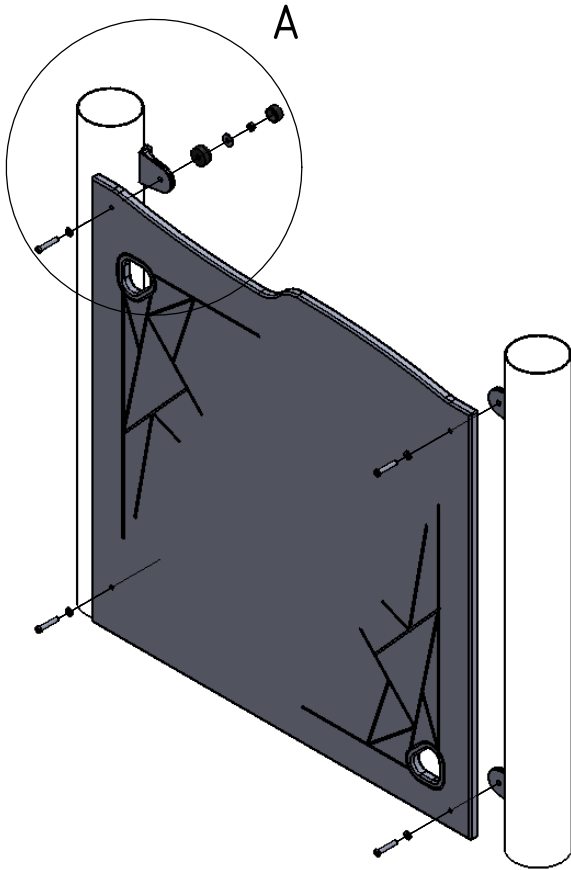

INST_11_68A

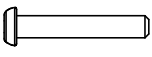

Nr	Σ	Element		
10	4		DIN 9021	6x18
16	4		-	K1_d21_B
17	4		-	Z1_d21_B
18	4		DIN 985	M6
22	4		DIN 125	6x12
25	4		ISO 7380	M6x35

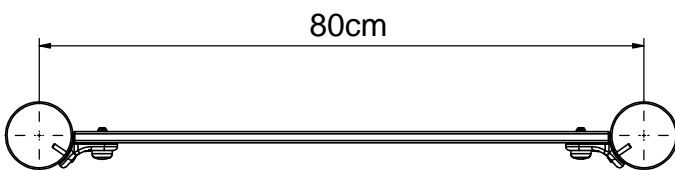
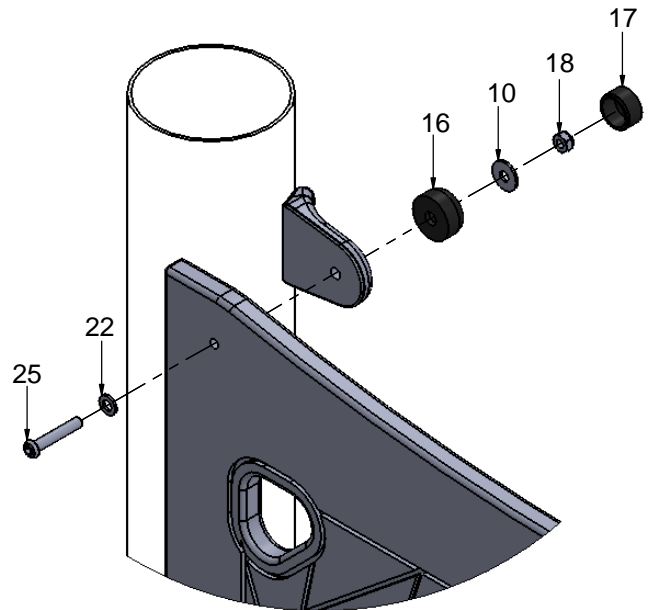

Nr	Σ	Element		
58	1		-	LOCTITE

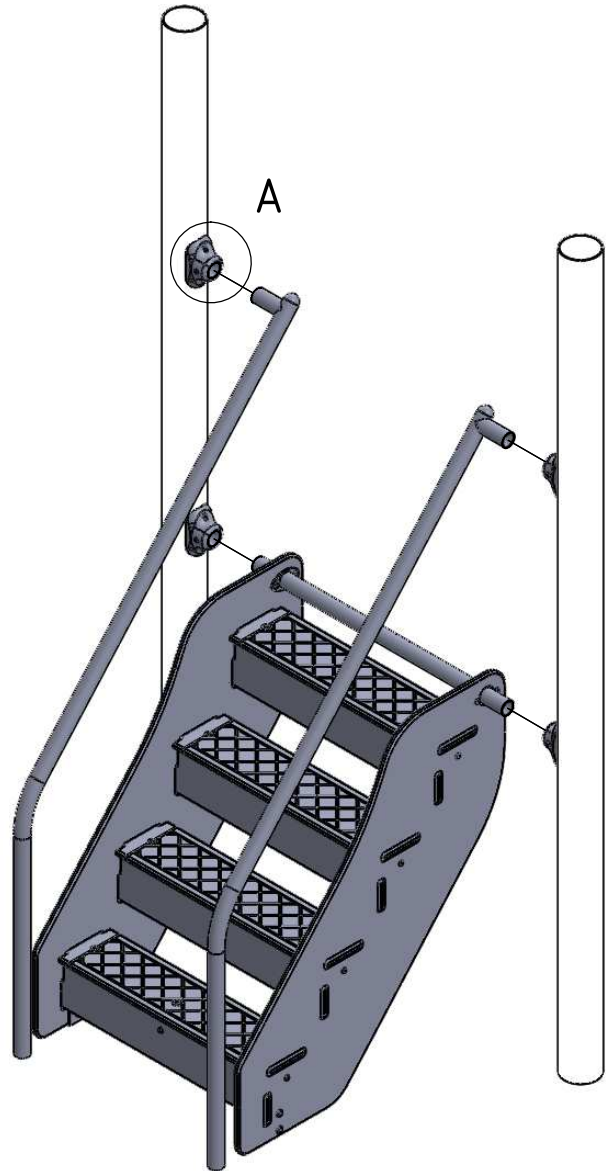
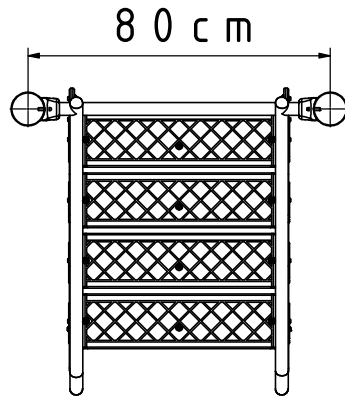
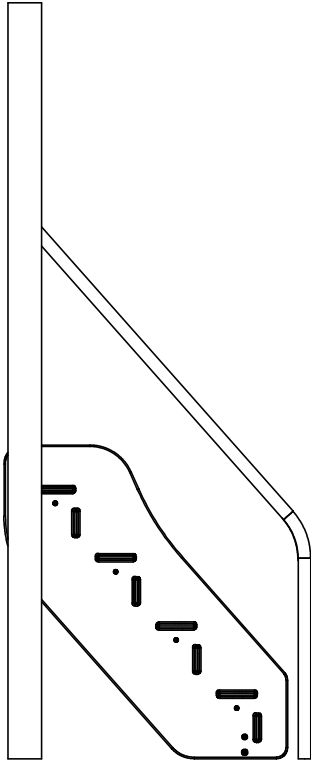



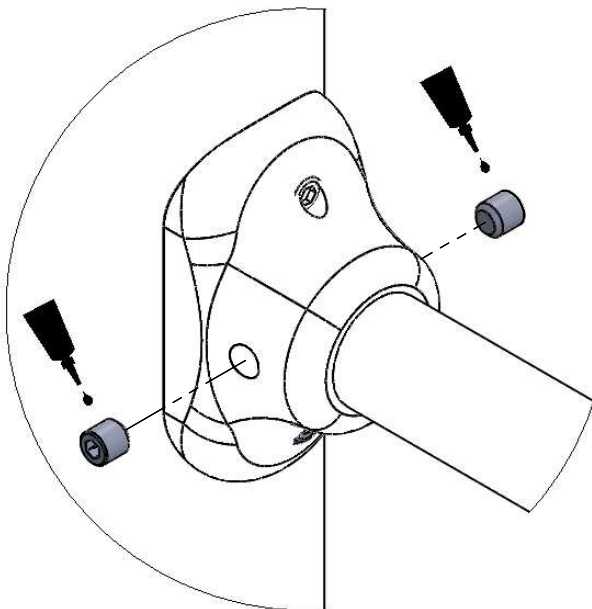

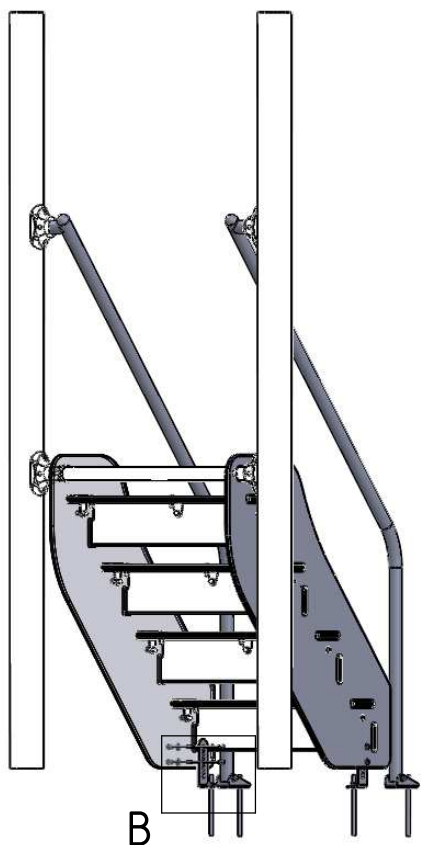

A (1 : 2)



F





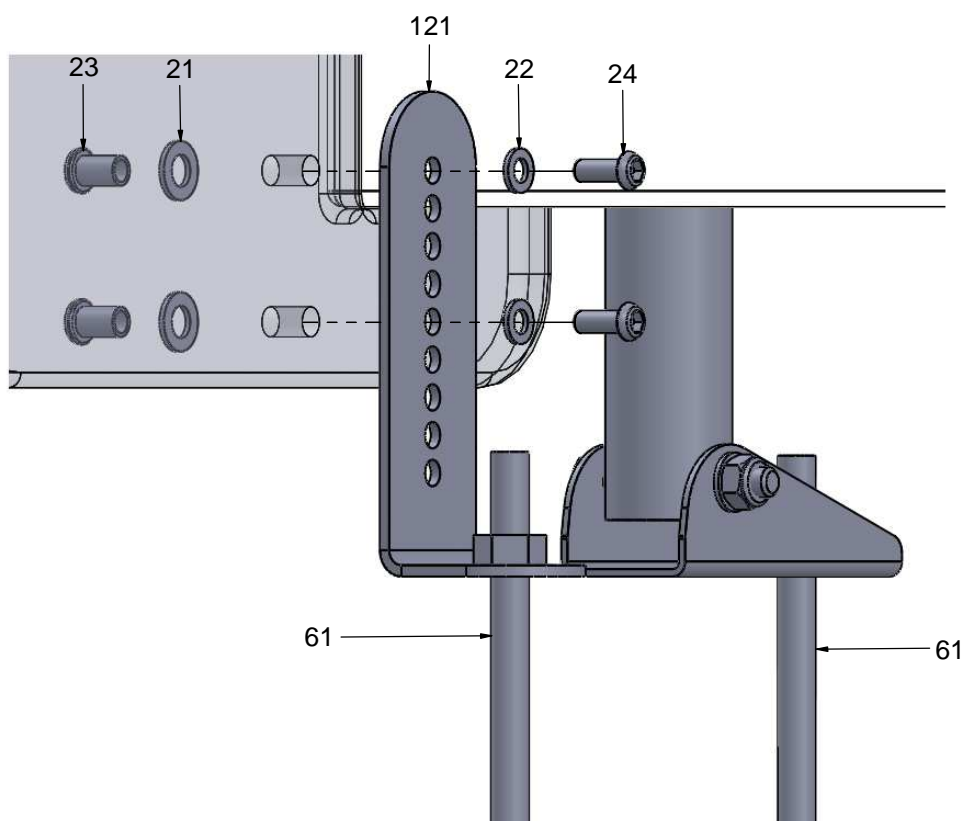

Nr	Σ	Element	DIN	ELEMENT
21	4		DIN 125	8x16
22	4		DIN 125	6x12
23	4		-	M6x12
24	4		ISO 7380	M6x16
61	4		-	KL105
121	2		-	7100_5_A2_g3_G_v1

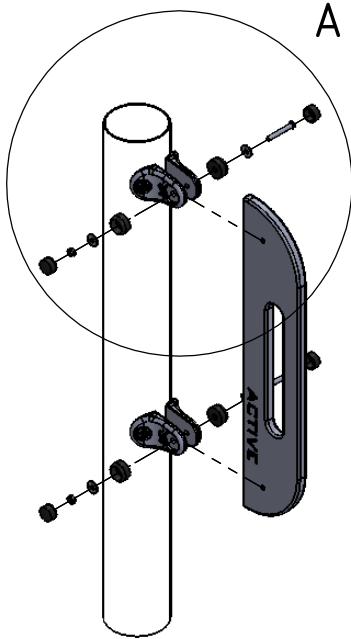
B (1 : 2)



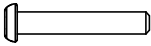

Nr	Σ	Element	DIN	ELEMENT
10	4		DIN 9021	6x18
16	4		-	K1_d21_B
17	4		-	Z1_d21_B
18	2		DIN 985	M6
51	2		ISO 7380	M6x45

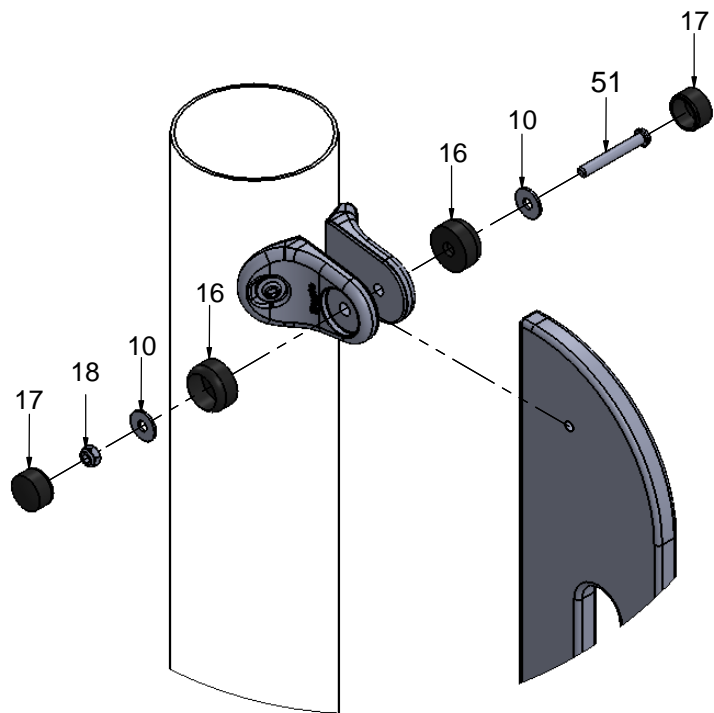

5

1109N
1109F



INST_11_18

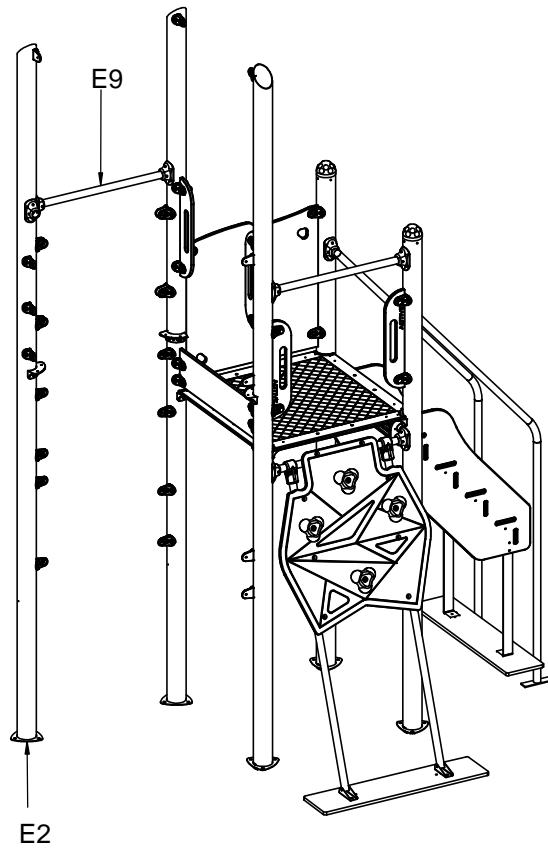



6

1109N
1109F

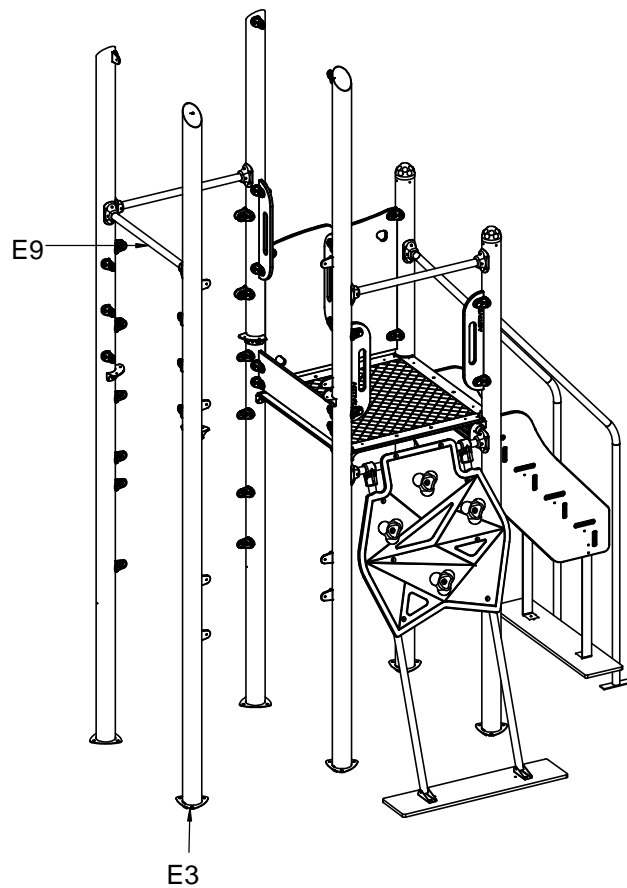

INST_11_18



Nr	Σ	Element		
58	1		-	LOCTITE

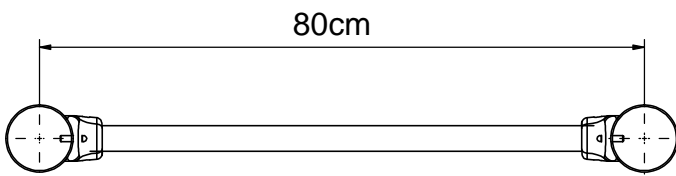
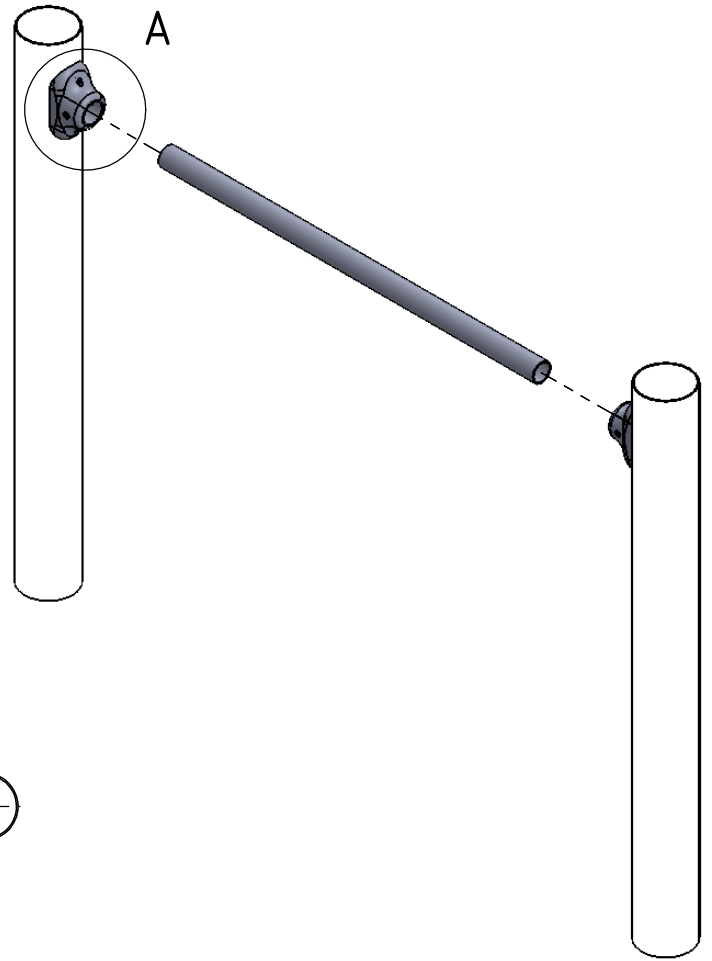

A (1 : 2)

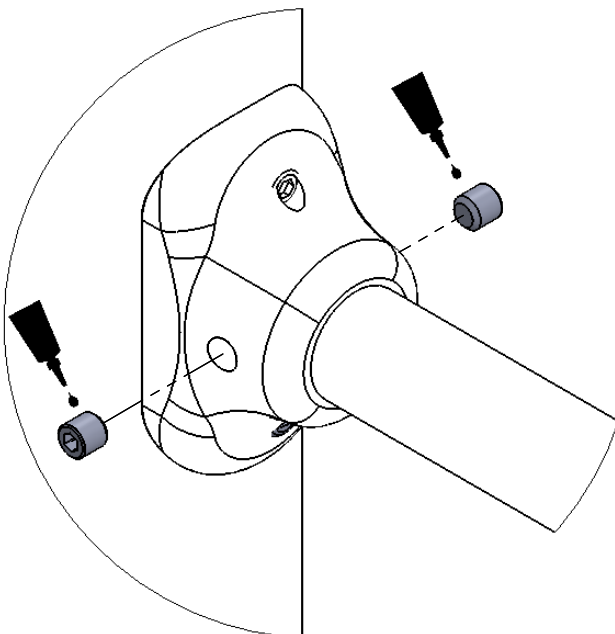

Nr. 5

7

1109N
1109F



INST_11_05
INST_11_37
INST_11_41
INST_11_68A

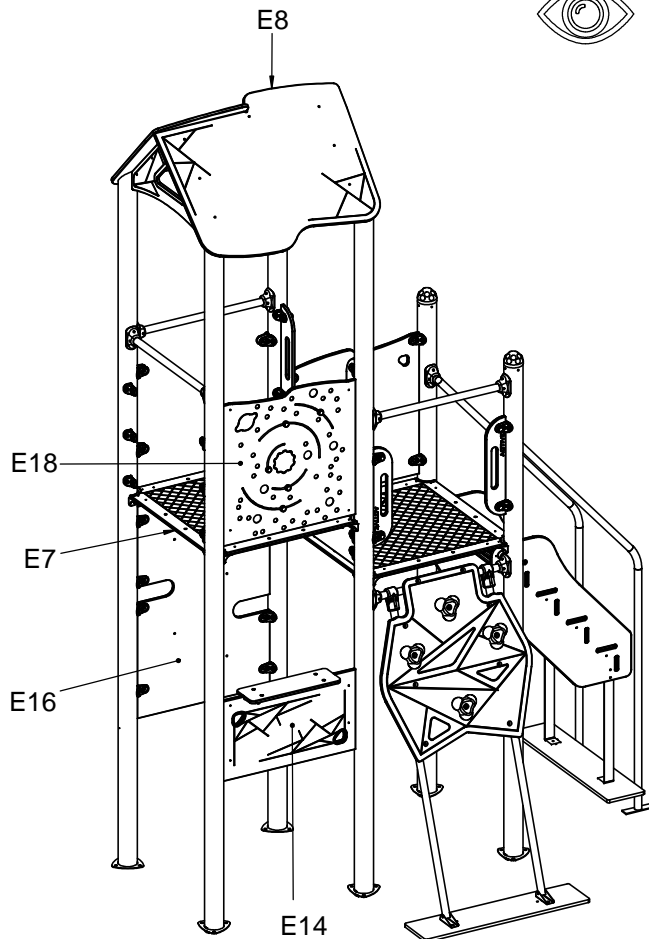

8

1109N
1109F





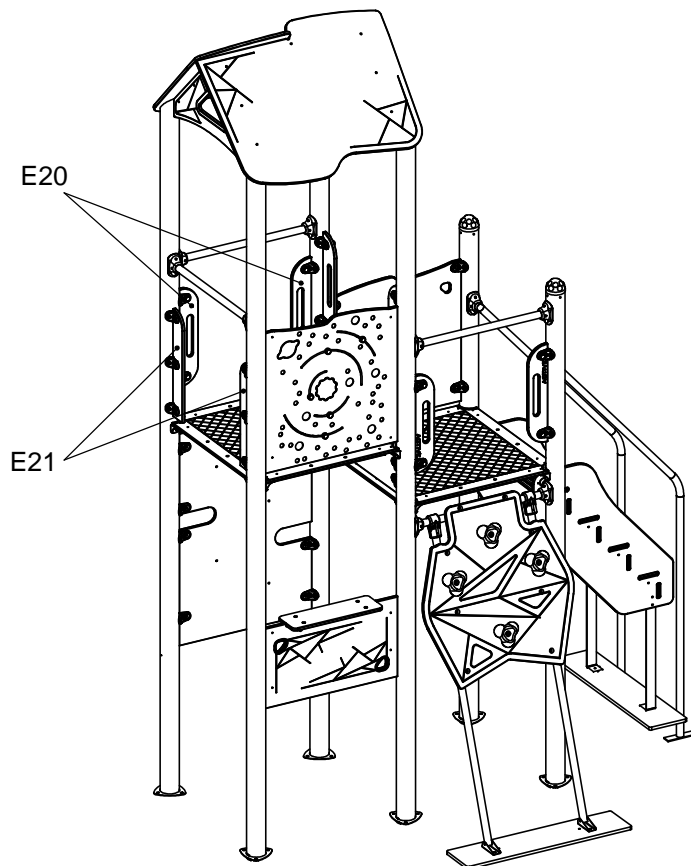

INST_11_68B
INST_11_68C

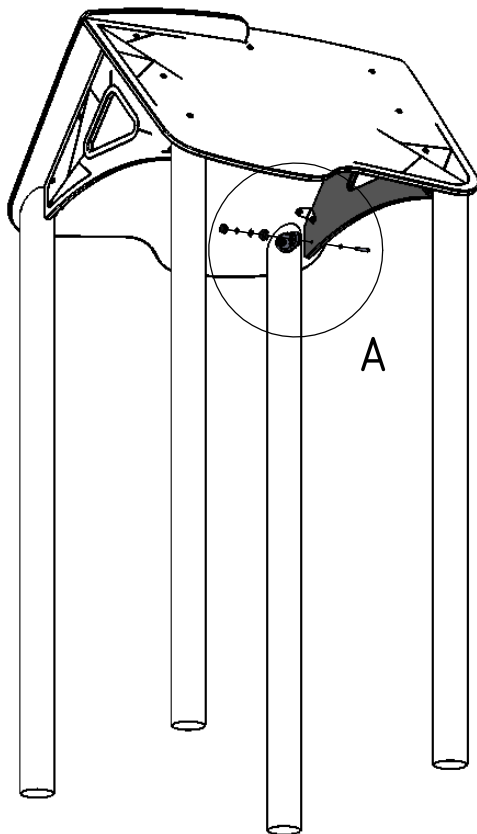
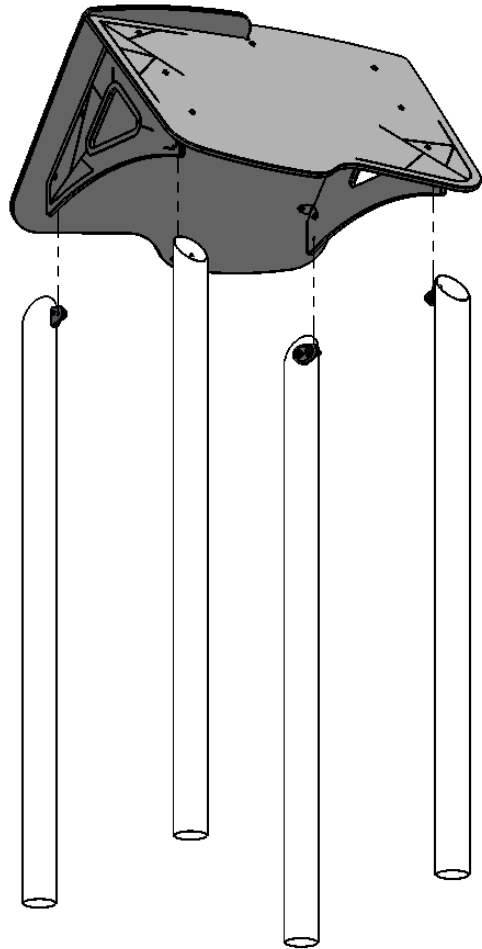

INST_11_05



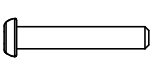



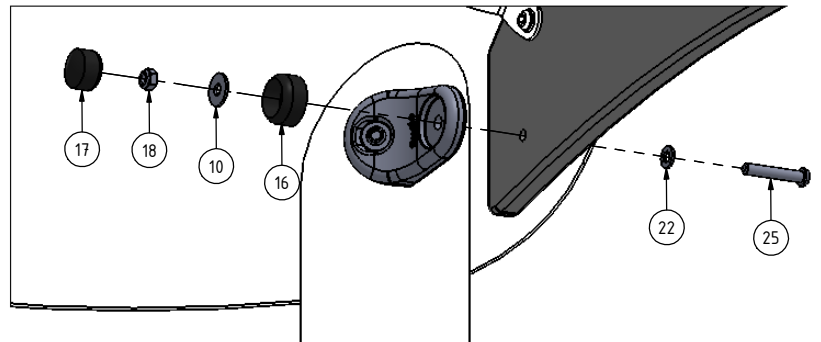

Nr	Σ	Element		
10	4		DIN 9021	6x18
16	4		-	K1_d21_B
17	4		-	Z1_d21_B
18	4		DIN 985	M6
22	4		DIN 125	6x12
25	4		ISO 7380	M6x35

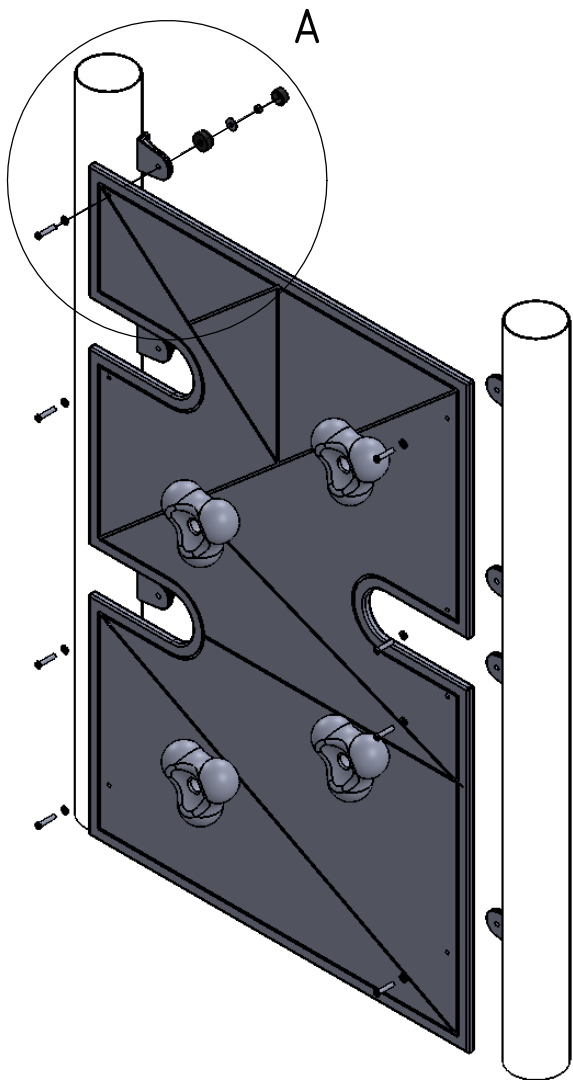
A (1 : 4)





INST_11_37

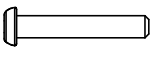

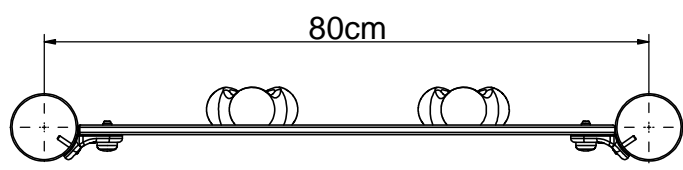
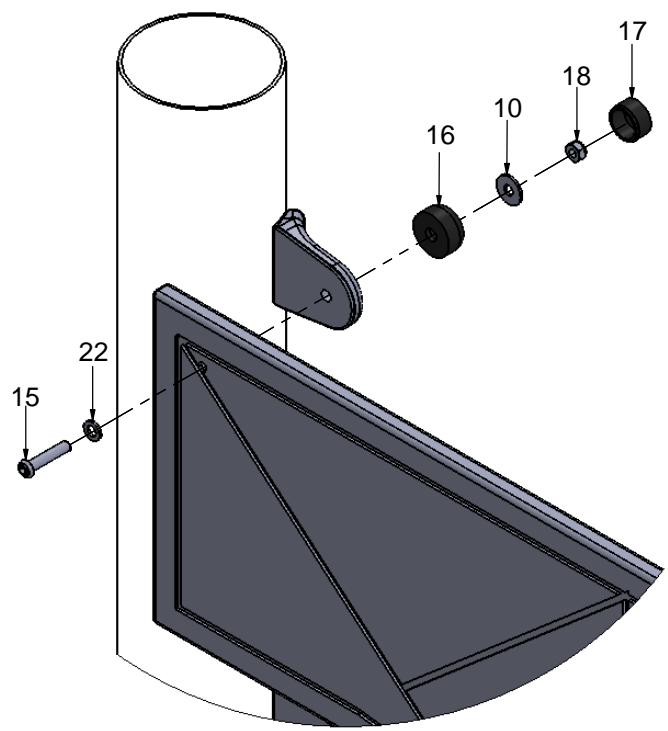
Nr	Σ	Element		
10	8		DIN 9021	6x18
16	8		-	K1_d21_B
17	8		-	Z1_d21_B
18	8		DIN 985	M6
22	8		DIN 125	6x12
15	8		ISO 7380	M6x30



Nr	Σ	Element	DIN	ELEMENT
21	8		DIN 125	8x16
139	8		DIN 7991	M6x16
23	8		-	M6x12

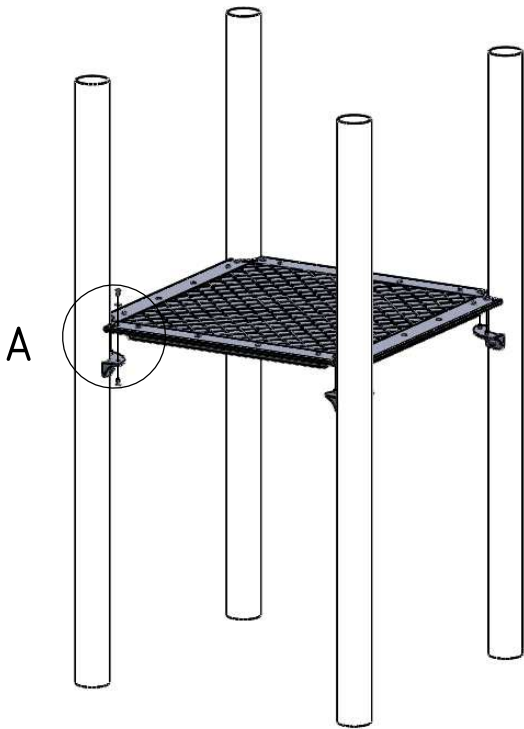



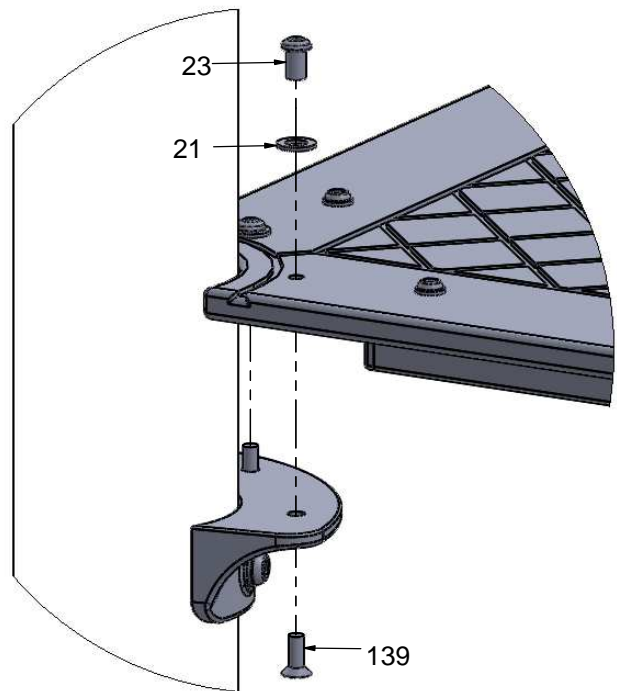

A (1 : 3)

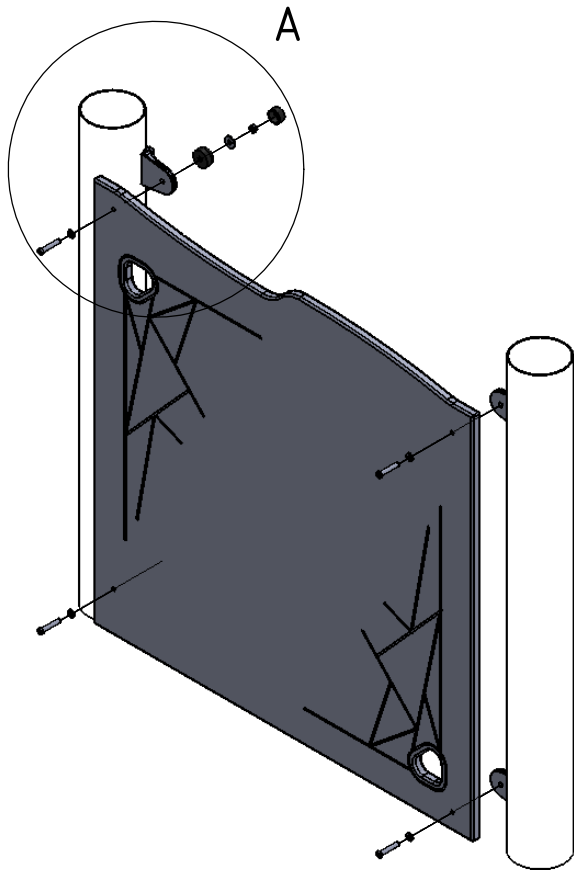



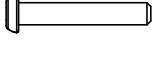

INST_11_68A

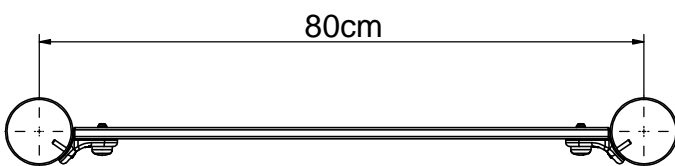
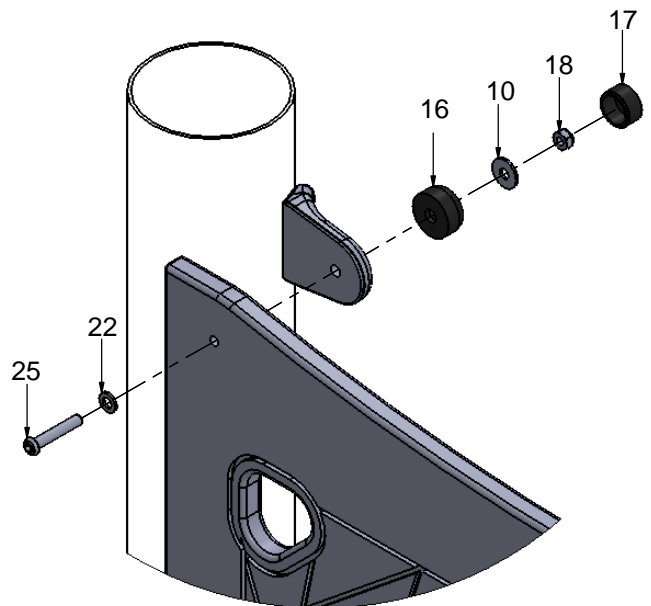

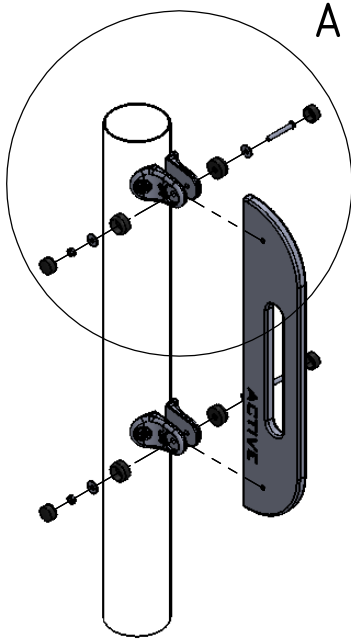
Nr	Σ	Element		
10	4		DIN 9021	6x18
16	4		-	K1_d21_B
17	4		-	Z1_d21_B
18	4		DIN 985	M6
22	4		DIN 125	6x12
25	4		ISO 7380	M6x35





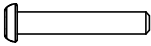

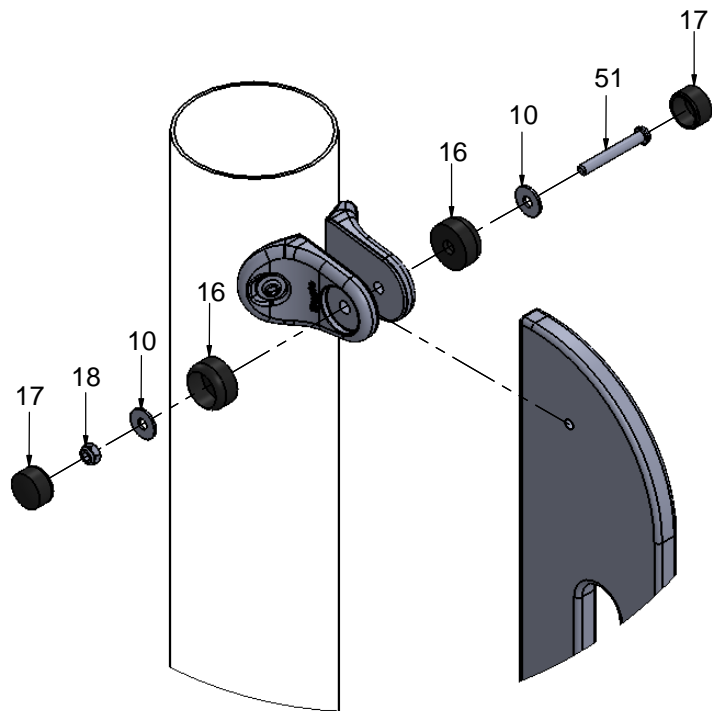

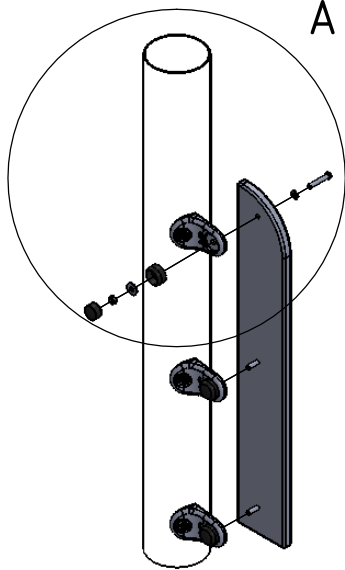

Nr	Σ	Element	DIN	ELEMENT
10	4		DIN 9021	6x18
16	4		-	K1_d21_B
17	4		-	Z1_d21_B
18	2		DIN 985	M6
51	2		ISO 7380	M6x45



INST_11_68C

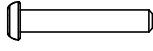

Nr	Σ	Element	DIN	ELEMENT
10	3		DIN 9021	6x18
16	3		-	K1_d21_B
17	3		-	Z1_d21_B
18	3		DIN 985	M6
25	3		ISO 7380	M6x35
22	3		DIN 125	6x12

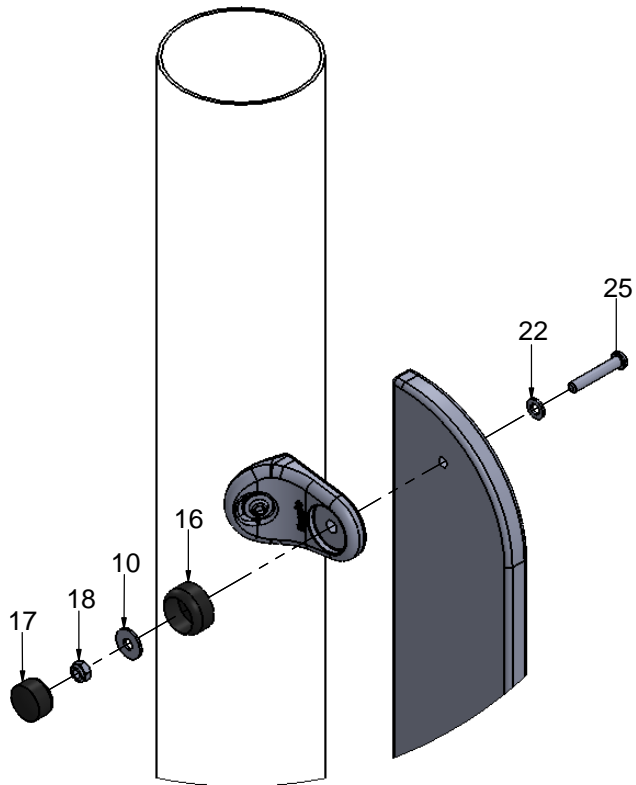

9

1109N
1109F



INST_11_70

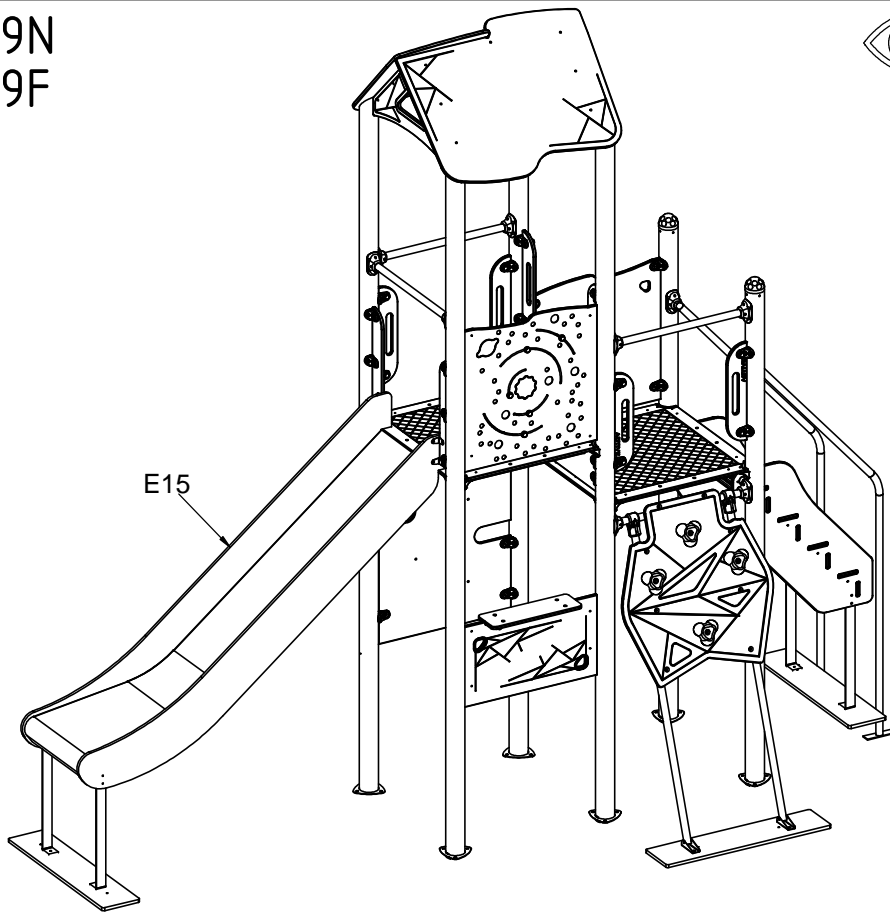

10

1109N
1109F



INST_Z_1

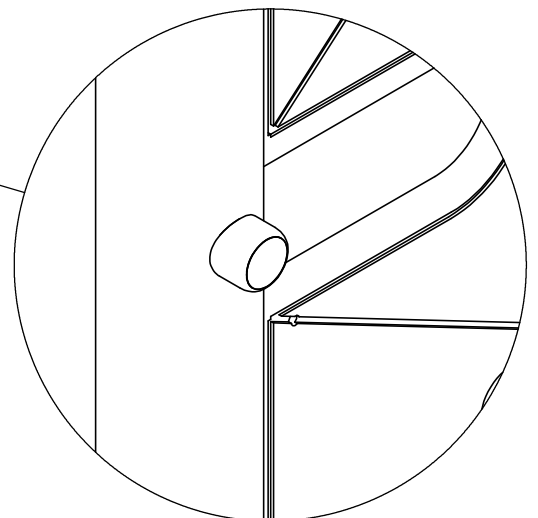
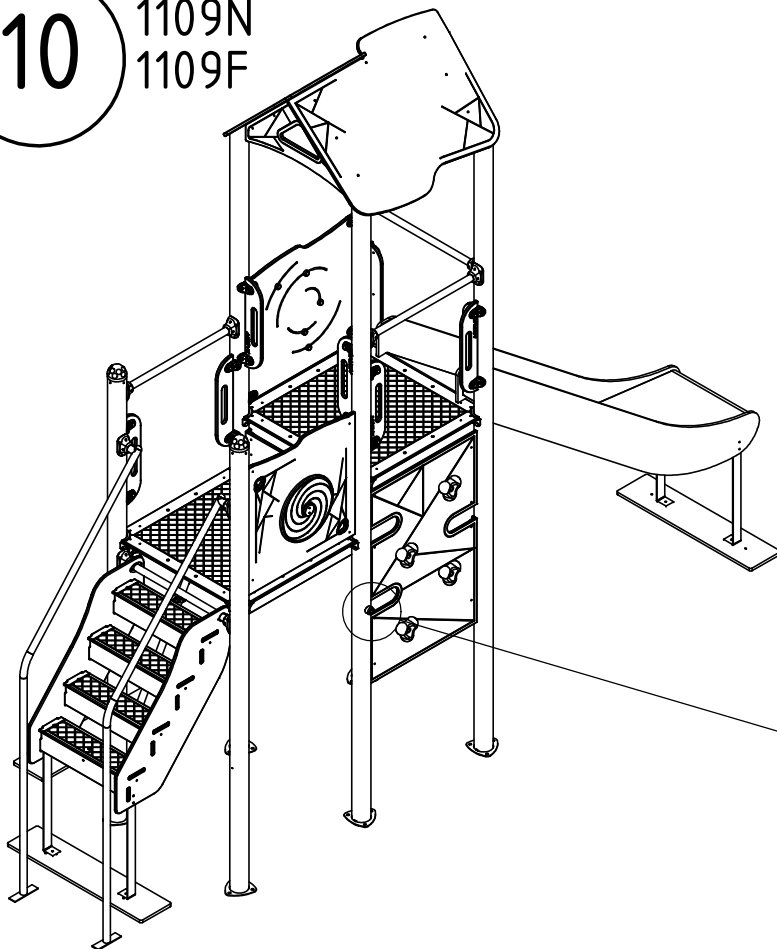

INST_11_70

A (1 : 3)

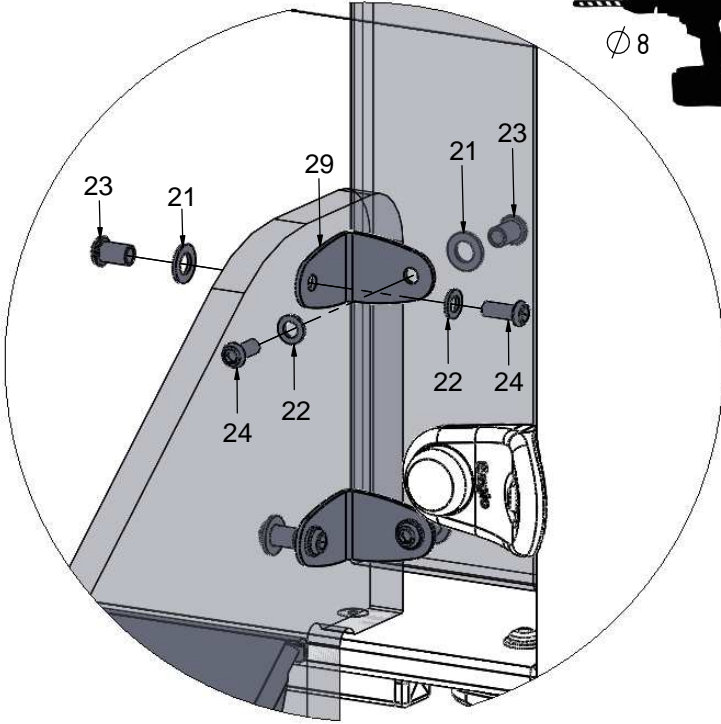
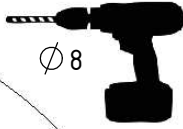

Nr	Σ	Element	DIN	ELEMENT
22	8		DIN 125	6x12
29	4		-	K_5_A2_g2_G_v2
23	8		-	M6x12
24	8		ISO 7380	M6x16
21	8		DIN 125	8x16

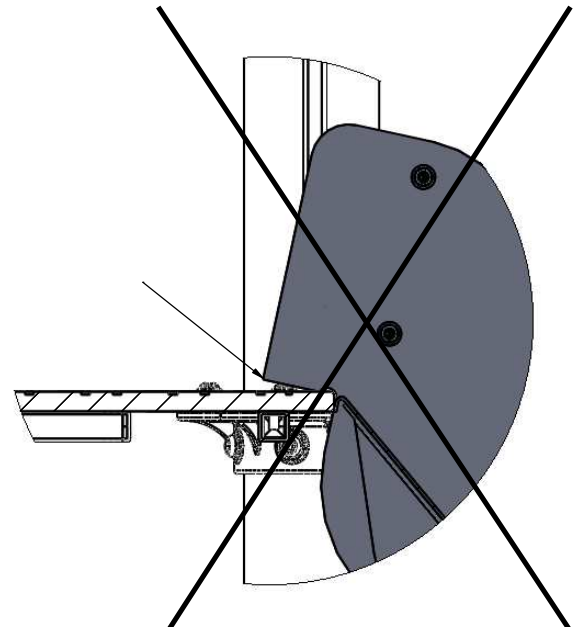
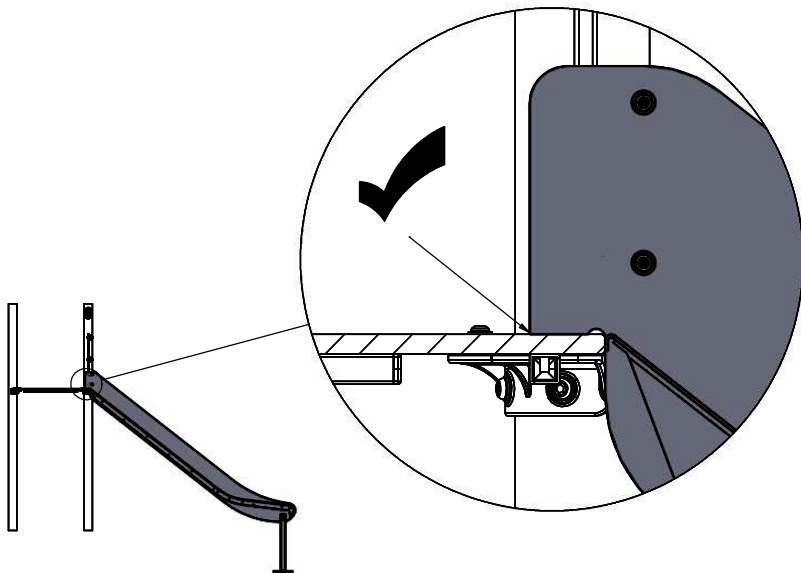
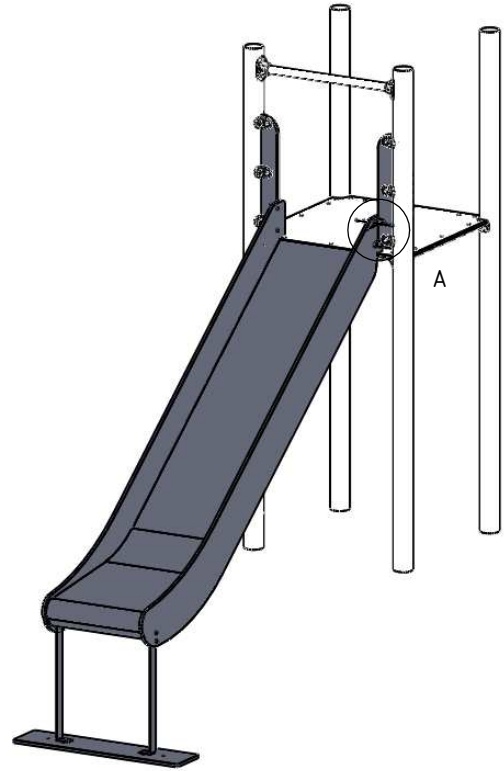
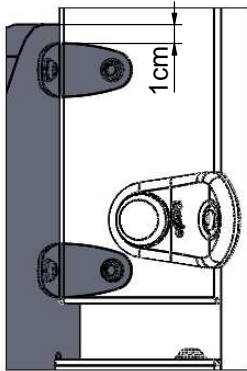



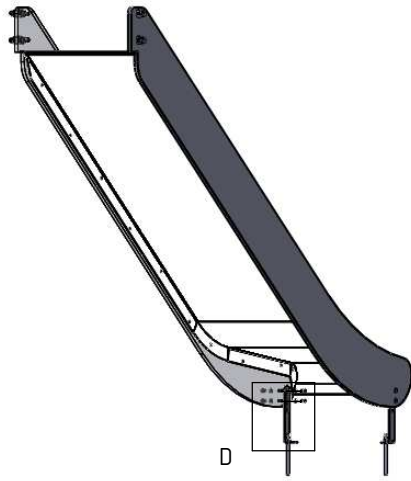

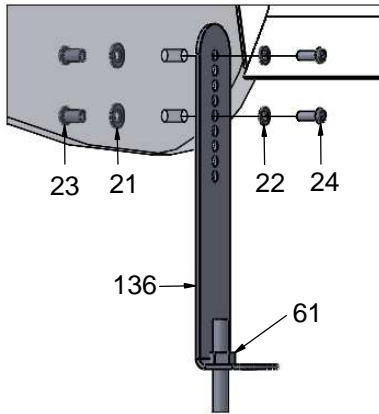

F - SL150



D (1 : 5)







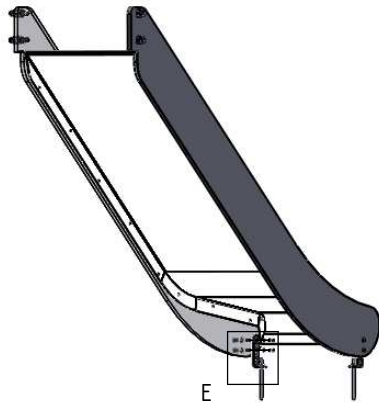

Nr	Σ	Element	DIN	ELEMENT
21	4		DIN 125	8x16
22	4		DIN 125	6x12
23	4		-	M6x12
24	4		ISO 7380	M6x16
61	2		-	KL105
136	2		-	1100_6_A2_g3_G_v1

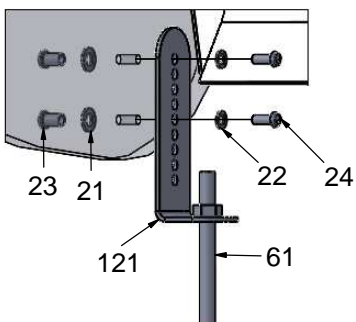
F - SL90, SL120, SL180





E (1 : 5)



Nr	Σ	Element	DIN	ELEMENT
21	4		DIN 125	8x16
22	4		DIN 125	6x12
23	4		-	M6x12
24	4		ISO 7380	M6x16
61	2		-	KL105
121	2		-	7100_5_A2_g3_G_v1

INST_Z_1

Nr	Σ	Element		
213	1		-	Z_NA_1
214	1		-	Z_NA_2

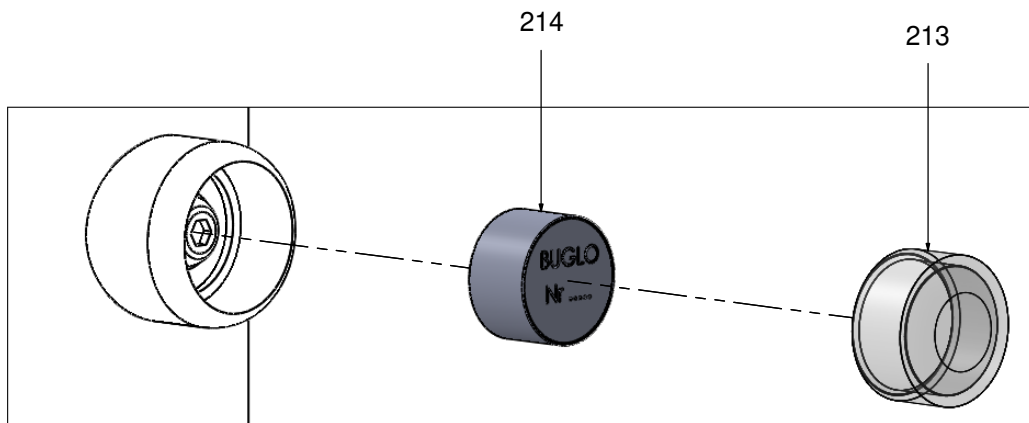
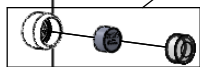

1109N

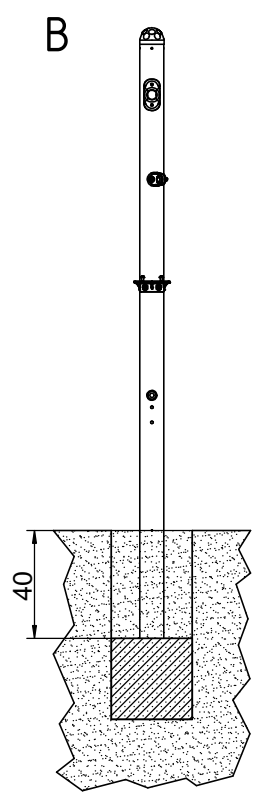
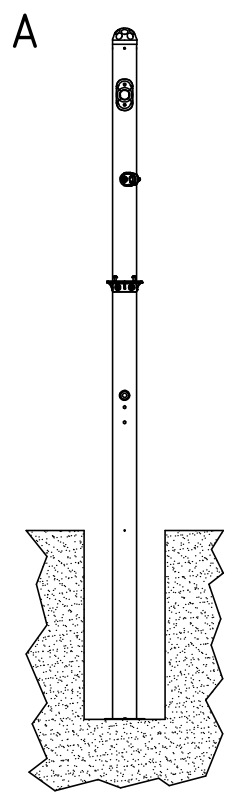
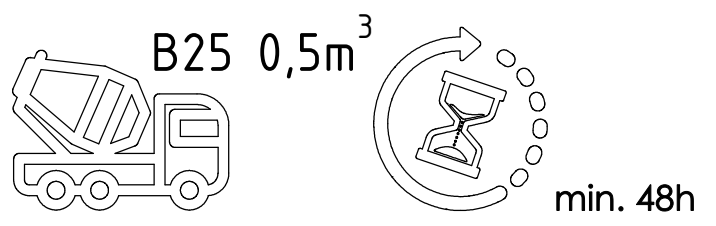
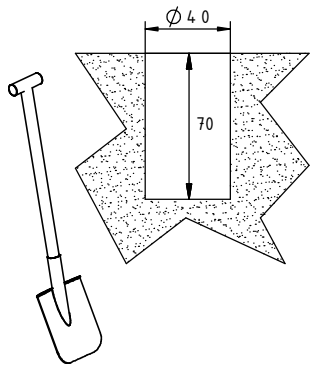
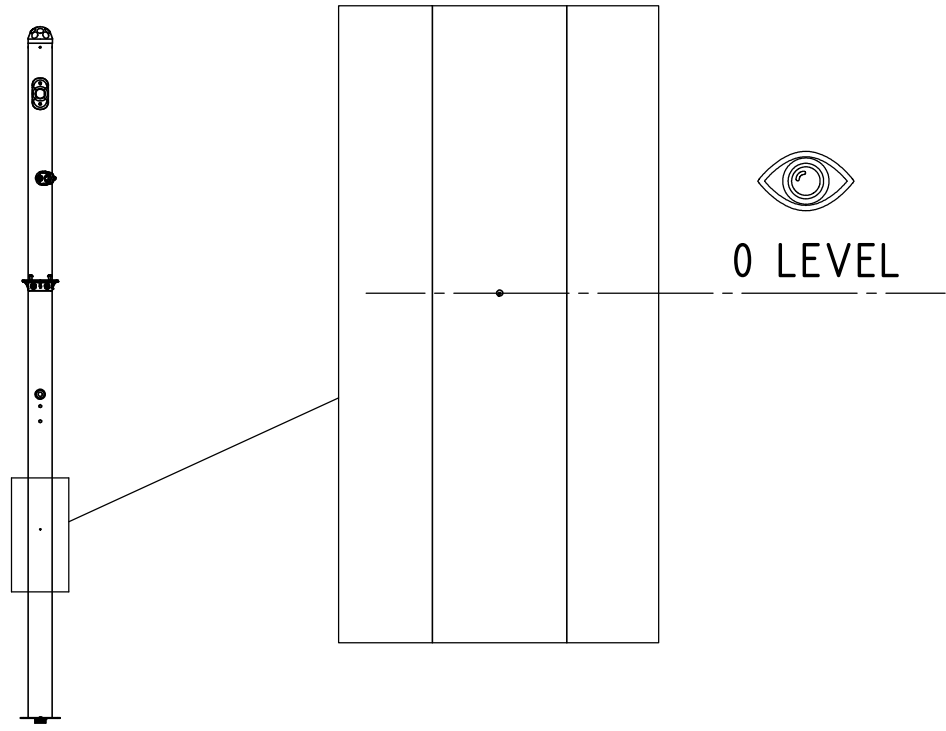

1109F

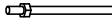
Nr	Σ	Element	DIN	ELEMENT
61	3		-	KL105

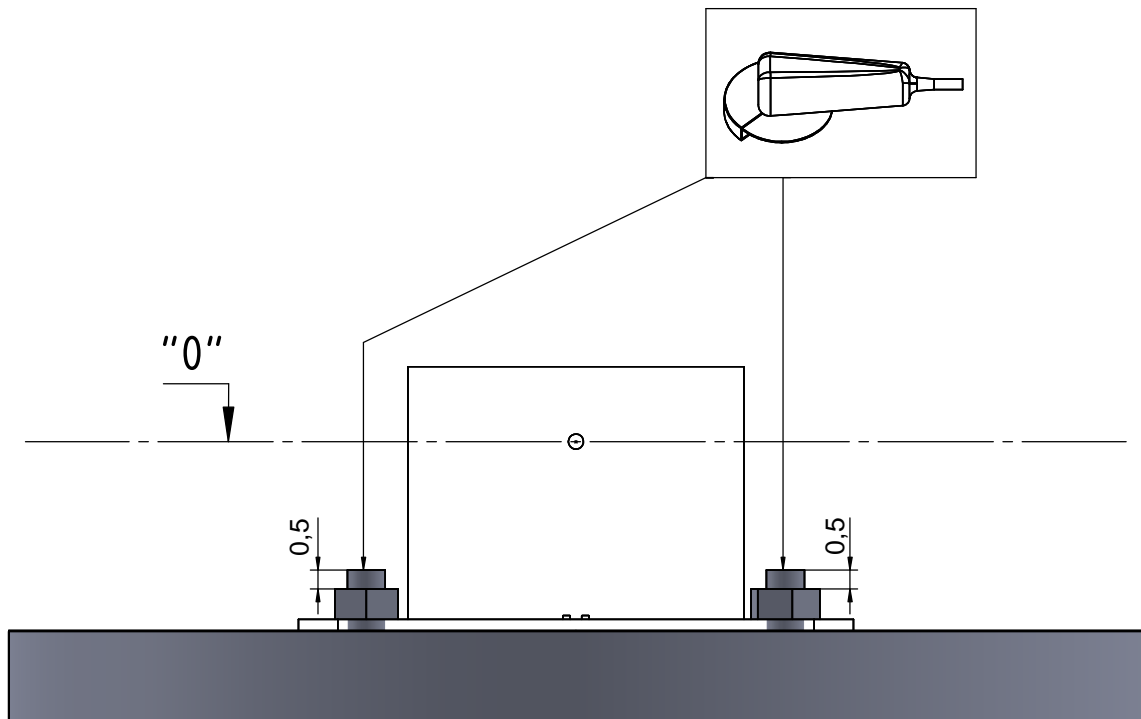
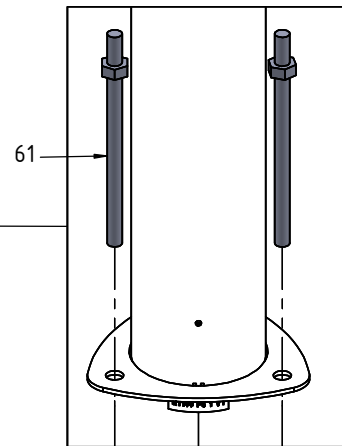
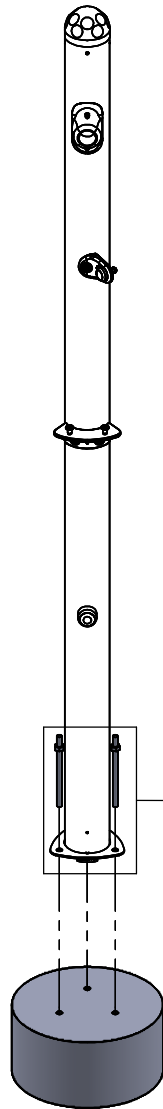
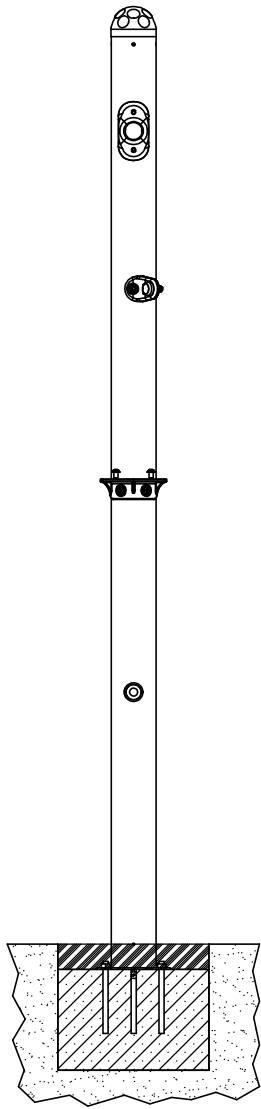

Tuotteen huolto-ohje

Leikkikenttävälineemme täyttävät EN-1176-1 : 2017- 12 -standardin turvallisuusvaatimukset.

On suotavaa ottaa yhteyttä tuotteen valmistajaan liittyen takuun alla olevien osien huoltotöihin. Vahingoittuneet maalipinnat tulee puhdistaa pölystä, rasvasta ja ruosteesta. Tämän jälkeen puhdistettu pinta tulee peittää ruostumattomalla pohjamaalilla ja sitten maalata kahdesti teräspinoille tarkoitetulla maalilla.

LeikkiSet Oy:n käyttämät väriyhdistelmät:

- 1) Harmaa - RAL 7035
- 2) Keltainen - RAL 1003
- 3) Sininen - RAL 5015
- 4) Punainen - RAL 3000
- 5) Vihreä - RAL 6018
- 6) Musta - RAL 9005
- 7) Violetti - RAL 4008
- 8) Antrasiitti - RAL 7016
- 9) Hopea - RAL 9006
- 10) Beige - RAL 1019
- 11) Oranssi - RAL 2009

Puu vaatii säännöllistä huolenpitoa. Ilmasto-olosuhteista, käyttöasteesta ja mekaanisista vaurioista riippuen on suositeltavaa uudistaa kyllästyskerros 2 - 5 vuoden kuluttua.

Suosittellemme käyttämään tuotteita: GORI 356 puunsuoja-ainetta ja NORDICA EKO 3330-12-BASE T pintamaalia (väri 1806), nämä löydät sivustolta www.teknos.com.

Suosittelavaa on, että osat jotka ovat ruostumatonta terästä puhdistetaan kerran vuodessa, jotta epäpuhtaudet eivät aiheuta värimuutoksia teräkseen. Pese puuvillaliinoilla ja veteen liuotetulla miedolla pesuaineella, esim. astianpesuaine. Puhdistuksen jälkeen huuhtelee vedellä ja pyyhi kuivaksi.

HUOMIO! Ruostumattoman teräksen puhdistukseen käytettävät puhdistusaineet eivät saa sisältää: klooria, suolaa, happoja tai valkaisuaineita. Jo pieni määrä näitä aineita voi aiheuttaa kromioksidipinnan pysyviä vaurioita

- 1) Kausittainen tarkastus - kun väline on aktiivisessa käytössä, tulee sen kunto tarkastaa viikoittain tai useammin. Samalla tulee tarkistaa mahdolliset välineeseen kohdistuneet ilkeivät teot.

Kausittainen tarkastus pitää sisällään:

- Rakenteiden vakauden tarkistaminen
- Yleinen tarkastus osien puuttumisen varalta
- Tarkistaminen halkeamien, terävien reunojen ja muiden vaurioiden varalta
- Välineen ympäristön siisteys
- Mahdollisen turva-alustan kunnon tarkistaminen

- 2) Välineen sisäinen valvonta - tulee suorittaa kerran kolmessa kuukaudessa. Se pitää sisällään yleistarkastuksen, minkä lisäksi tulee tarkistaa myös välineen toiminnot.

Sisäinen valvonta pitää sisällään:

- Mahdollisen turva-alueen pinnan tarkistaminen ja mittaaminen (jos pinta on yli 10cm alle oikean tason, pitää sitä täydentää)
- Kaikki ruuvit ja mahdolliset kaapelit sekä verkot tulee kiristää

3) Vuositarkastus (pakollinen)

- Rakenteiden vakauden tarkistaminen
- Mahdollisten ruostevaurioiden tarkastaminen ja korjaaminen
- Perustusten tarkistaminen
- Mahdollisen turva-alueen pinnan tarkistaminen ja mittaaminen (Jos pinta on yli 10cm alle oikean tason, pitää sitä täydentää)

Kaikilla laitteilla on oltava säännöllinen tarkastusvalvonta. Tarkastuksen tekijän tulee kirjata tiedot tarkastuksesta ylös.